

ARB HILUX 2002 ON COMBINATION BULL BAR

READ FITTING INSTRUCTIONS CAREFULLY BEFORE FITTING BAR TO VEHICLE

THIS PRODUCT FITS BOTH SRS & NON SRS VEHICLES

PRODUCT NUMBERS: 3414220 FLARED VEHICLES

3414210 NON FLARED VEHICLES

WARNING

FOR VEHICLES EQUIPPED WITH SRS AIRBAG
WHEN INSTALLED IN ACCORDANCE WITH THESE INSTRUCTIONS, THE FRONT PROTECTION BAR DOES NOT AFFECT OPERATION OF THE SRS AIRBAG.

TAKE NOTE OF THE FOLLOWING:

- **THIS PRODUCT MUST BE INSTALLED EXACTLY AS PER THESE INSTRUCTIONS USING ONLY THE HARDWARE SUPPLIED.**
- **IN THE EVENT OF DAMAGE TO ANY BULL BAR COMPONENT, CONTACT YOUR NEAREST AUTHORISED ARB STOCKIST. REPAIRS OR MODIFICATIONS TO THE IMPACT ABSORPTION SYSTEM MUST NOT BE ATTEMPTED.**
- **DO NOT USE THIS PRODUCT FOR ANY VEHICLE MAKE OR MODEL, OTHER THAN THOSE SPECIFIED BY ARB.**
- **DO NOT REMOVE LABELS FROM THIS BULL BAR.**
- **THIS PRODUCT OR ITS FIXING MUST NOT BE MODIFIED IN ANY WAY.**

IMPORTANT

This winch bumper is suitable only for Warn 8000lb, 9000lb and 9500lb winch.

FITTING KIT NUMBER**6171439**

USE	PART No	QTY	DESCRIPTION
CONTROL BOX BRACKET	3756209	1	CONTROL BOX BRACKET
	6151021	2	BOLT M8 X 20mm
	6151132	2	NUT FLANGE M8
	4581044	2	WASHER FLAT M8
NUMBER PLATE AND NUMBER PLATE BRACKET	3751451	1	NUMBER PLATE BRACKET
	6151017	4	BOLT M6 X 16mm
	6151046	4	WASHER FLAT M6
	6151128	4	NUT FLANGE M6
CHASSIS BRACKETS TO BULL BAR	3751666L	1	CHASSIS BRACKET (LEFT)
	3751666R	1	CHASSIS BRACKET (RIGHT)
	6151094	4	BOLT M12 X 30mm
	4581070	4	WASHER M12 HEAVY DUTY
	4581071	4	WASHER SHOULDER M12
	4581049	4	WASHER FLAT M12
	4581050	4	WASHER SPRING M12
	6151135	4	NUT M12
8-9000lb WINCH TO PAN	4581040	4	WASHER FLAT 3/8"
CHASSIS BRACKET TO CHASSIS SRS	4581067	2	REINFORCING PLATE
	6151291	2	EXTENSION BOLT PLATE M12 X 35mm
	6151094	4	BOLT M12 X 30mm
	6151135	2	NUT M12
	4581049	6	WASHER FLAT M12
	4581050	6	WASHER SPRING M12
ORIGINAL CRUSH CAN TO BAR	6151083	2	BOLT M8 X 35mm
	4581044	2	WASHER FLAT M8
	4581096	2	M8 HEAVY DUTY WASHER
	4581046	2	WASHER SPRING M8
CRUSH CAN ADJUSTER	4581088	2	CRUSH CAN ADJUSTER
	6151189	2	NUT M12
CRUSH CAN EXTENSION	3193620	2	PLATE CRUSH CAN EXTENSION
	4581044	4	WASHER FLAT M8
	6151021	4	BOLT M8 X 20mm
	6151132	4	NUT FLANGE M8
TOW HOOK	6151135	2	NUT M12
	4581049	2	WASHER FLAT M12
	4581050	2	WASHER SPRING M12
BUFFERS AND INDICATORS	3500170	1	BUFFER KIT
	3500080	1	ARB INDICATOR KIT
PANEL WINCH COVER	6521036	1	COVER BLACK
	6151256	2	SCREW BUTTON M6 X 16mm
	4581304	2	WASHER FLAT M6 S/S
	6191001	1	EXTRUSION CHANNEL
	6151128	2	NUT FLANGE M6
CHASSIS BRACKET TO CHASSIS / BOLTS / NON SRS	6151232	6	BOLT M10 X 30mm
	4581040	12	WASHER FLAT M10
	4581048	6	WASHER SPRING M10
	6151026	6	NUT M10
CABLE TIES	180302	4	CABLE TIES

FOR BULL BARS WITHOUT A WINCH



1. Fit the indicators into bar.
2. Fit rubber buffers to the bull bar using 6mm flange nuts supplied in the buffer kit.



3. Fit rubber extrusion around cover plate and fit to bull bar using 6mm domed head bolts and flange nuts.



4. Fit the number plate to the lower holes in the bull bar to hide the lower winch opening.

FOR BULL BARS WITH A WINCH



1. Fit the indicators into bar.
2. Fit rubber buffers to the bull bar using 6mm flange nuts supplied in the buffer kit.

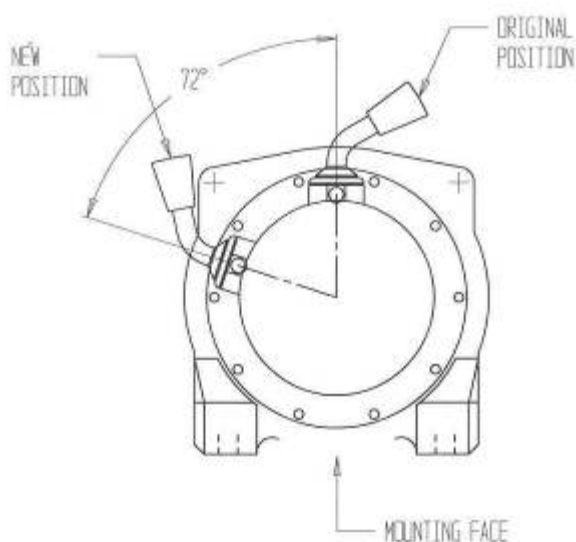

3. For ease of operation, the clutch handle should be rotated 72° in an anti clockwise direction. The motor end does not require rotating.
4. Undo and remove all capped head screws from gearbox end. Gently raise the gearbox just enough to rotate to correct position. Take care not to lift the assembly more than a couple of millimeters while rotating to correct position to avoid unmeshing the gears.
5. Refit all capped head screws and tighten.

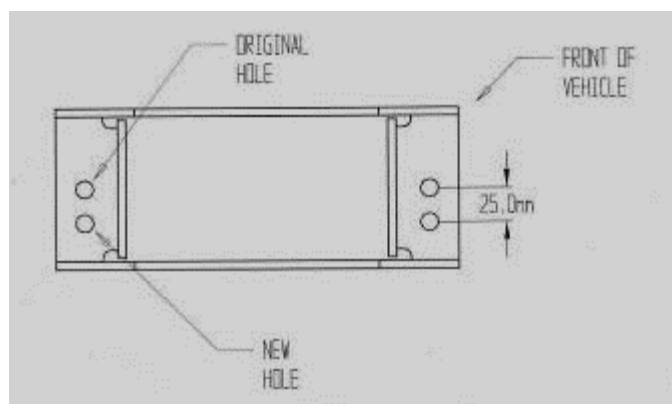

6. Drill new mounting holes in the roller fairlead as shown.



7. Fit number plate bracket to bull bar using 6mm hardware.
8. Fit control box bracket to bull bar using 8mm hardware.



9. If fitting the **XP 9.5 winch**, remove the cover from the control box.

For any other winch, go to step 16.

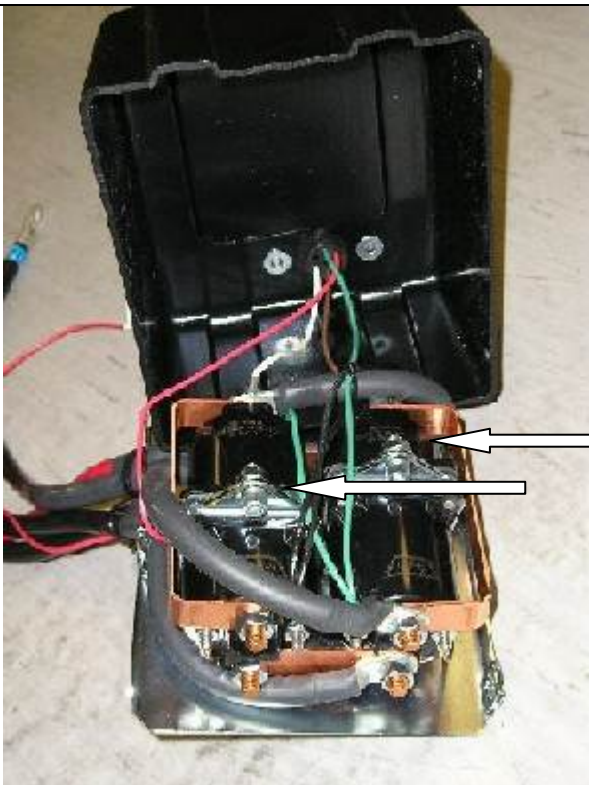

10. Remove the two cap screws, nuts and spacer washers that hold the four solenoids in place.



11. Remove the four solenoids from the base of the control box using the copper bus bar as an aid and hold to one side.

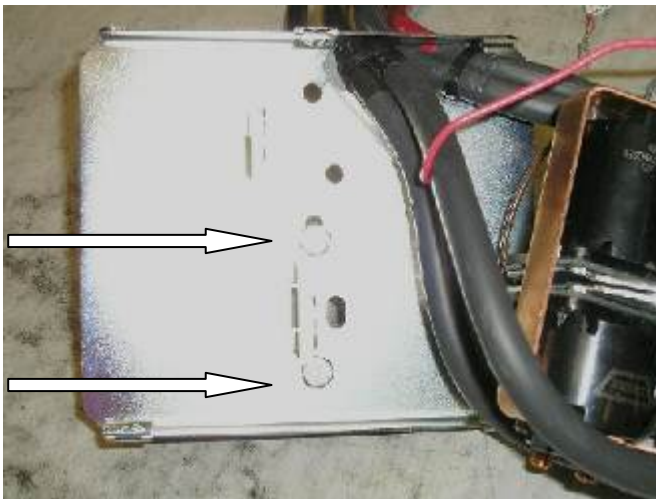

Before

12. Remove the two bolts in the base of the control box and reposition them into the more centralised holes

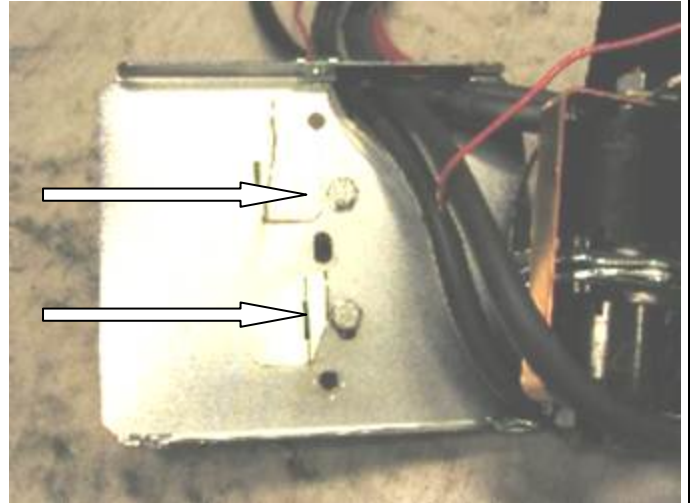

After



13. Place the 4 solenoids over the 2 metal stands that are facing upwards. Make sure they line up with the holes in the base.



14. Replace the 2 cap screws, washers and nuts removed in step 10 above into original holes.
15. Replace the black cover and refit the three cover screws (**DO NOT OVER TIGHTEN**)



16. Fit the control box to control box bracket using original control box nuts. Adjust so it fits evenly in the bull bar cutout and tighten nuts firmly.



17. Position the winch on a bench face up.
18. Lower bull bar on top of the winch and align the holes and fit 3/8" bolts etc to the top holes.



19. Place the roller fairlead in the bar cutout over the lower holes and fasten using 3/8" Warn hardware and four 3/8" flat washers supplied in the bolt kit.



20. To tighten bolts that hold the roller fairlead to the bar, remove the vertical rollers using circlip pliers.

21. When all bolts are in position and the winch is centralised in the bar, tighten all bolts firmly and replace the vertical rollers and circlips.



22. Wire up the winch as per Warn Owners manual. Cables tie cables clear of all moving parts and sharp edges with cable ties supplied.

23. Fit number plate to the bracket

PLACE GROUND EARTH UNDER TENSION BAR OF WINCH



WINCH HANDLE ON LHS OF BAR.

AIR BAG EQUIPPED VEHICLES ONLY

FOR NON AIR BAG VEHICLES GO TO PAGE 12

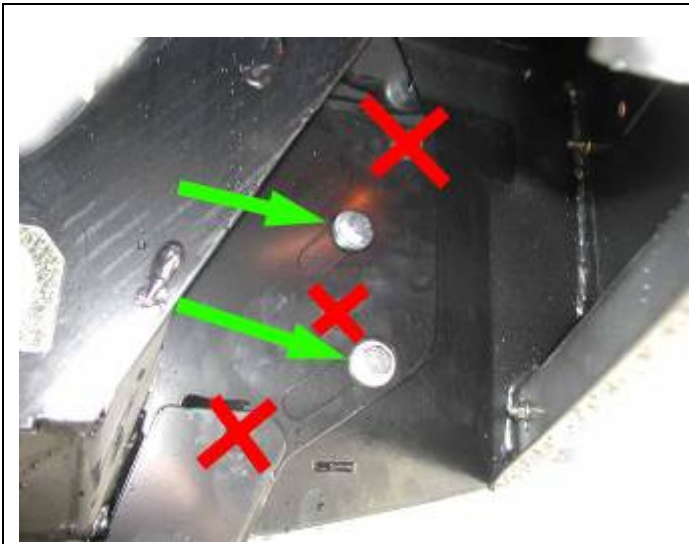

1. Assemble the two chassis brackets to the bull bar using two per side M12 x 30mm bolts, M12 heavy duty washers, shoulder washers, flat washers, spring washers and nuts. Tighten firmly.

ONLY USE THE SLOTS FOR AIR BAG EQUIPPED VEHICLES

VIEW FROM UNDERSIDE OF BULL BAR

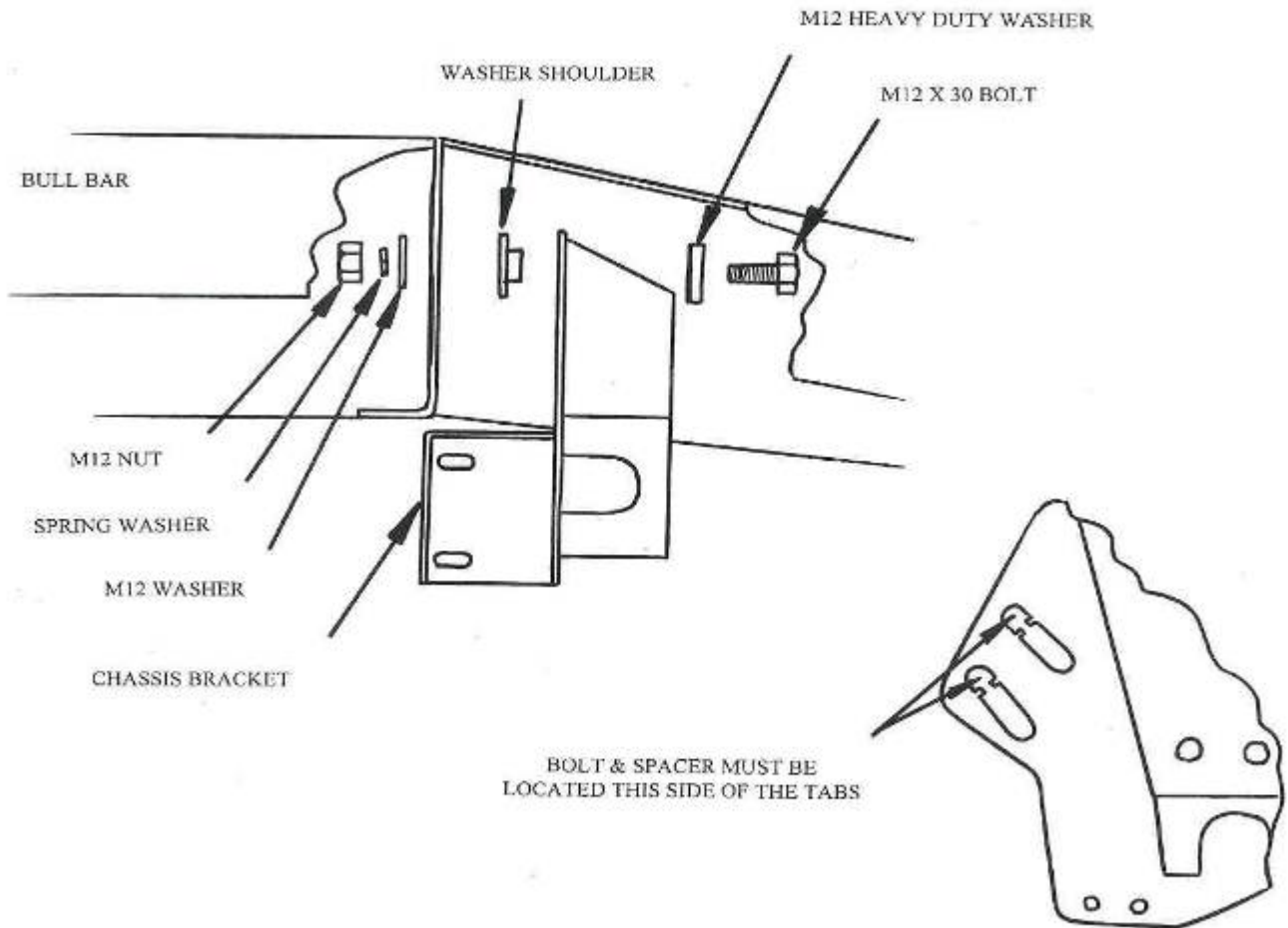

SIDE VIEW OF LH CHASSIS BRACKET



2. Remove the bumper bar, recovery hook, transport hook and packing plate from the vehicle. Discard transport hook and packing plate.
3. Remove the crush cans from the front of the chassis and set aside for later installment.
4. Check the chassis rail on vehicle for weld spatter as it will affect alignment of bull bar and remove spatter if necessary.

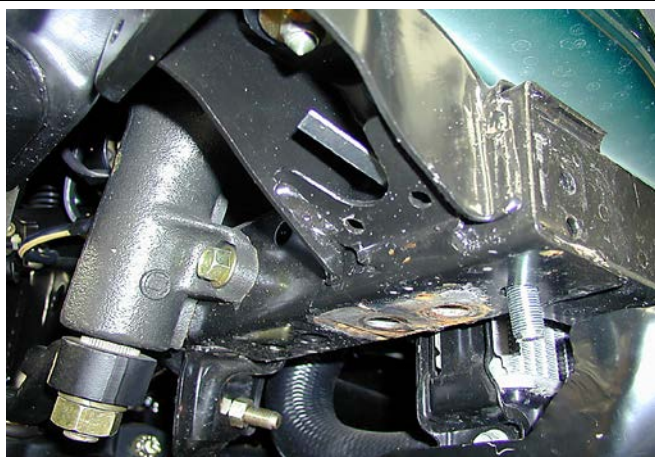

5. Install the M12 x 35mm captive bolt through the chassis access hole.
6. Push the captive bolt down through the bottom forward chassis hole.

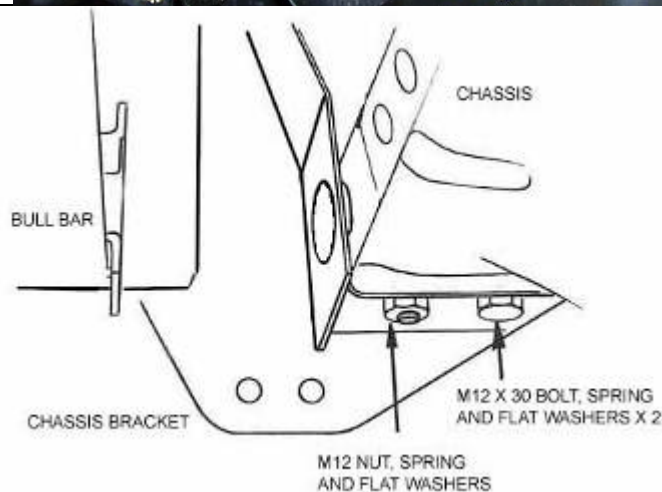

7. Position the bull bar so the chassis brackets are against the front crossmember and under chassis rails with captive bolt located through the front hole of chassis brackets.

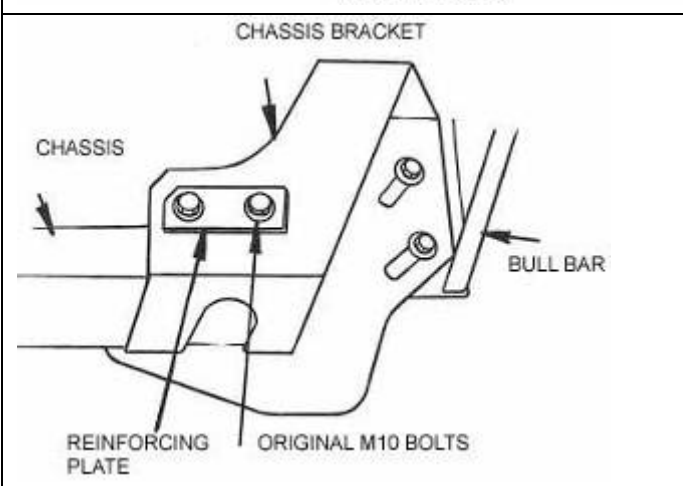

8. Fit four M12 x 30mm bolts, spring washers and flat washers (lower rear) and four M10 x 30mm bolts (original), flat washers and reinforcing plate (side mounts).
9. Align the bull bar in correct relationship to the vehicle and fully tighten the bolts.

10. Place the M8 heavy-duty washer between the chassis and the crush can. Refit the crush cans to the front of the chassis using M8 x 35mm bolts, spring washer and flat washers and fully tighten using a socket extension

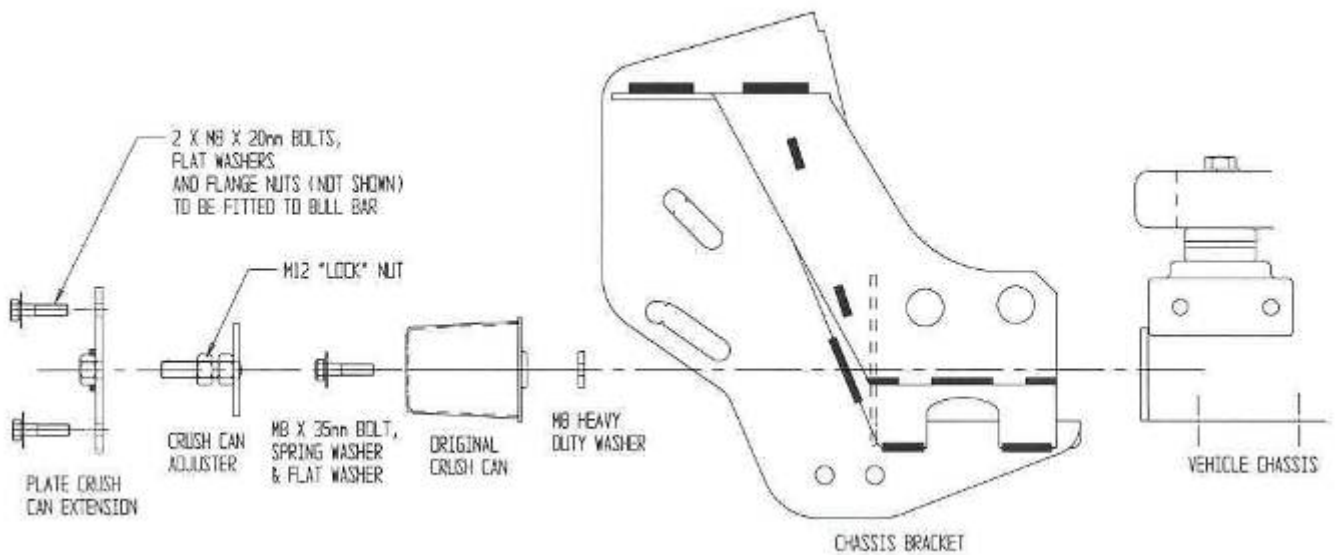

11. Assemble an M12 nut to each crush can adjuster and screw fully into the plate. Do not tighten as this will need to be adjusted later. Loosely bolt the plate to the bull bar using M8 X 20 bolts, flat washers and flange nuts. NOTE: The holes in the plate are offset (left and right handed). Align the extension bolt with the center of the crush can face then tighten the bolts. Wind each adjuster bolt out until it is firmly against the crush cans and tighten the lock nut.



12. Wire up the indicator looms to the vehicle indicator loom using the Scotchloks supplied. Test to ensure the indicators function correctly.
13. Assemble the tow hook using the original bolts and M12 flat washers, spring washers and nuts.

NON AIR BAG EQUIPPED VEHICLES ONLY



1. Remove the bumper bar, recovery hook, transport hook and packing plate from the vehicle. Discard transport hook and packing plate.
2. Remove the crush cans from the front of the chassis and set aside for later installment.

Check the chassis rail on vehicle for weld spatter as it will affect alignment of bull bar and remove spatter if necessary.

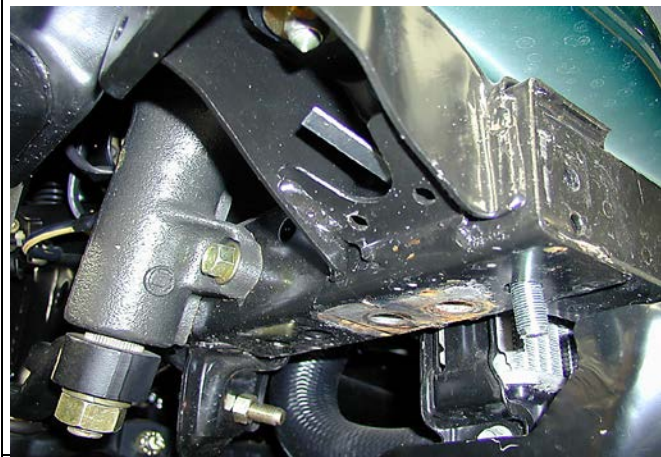

3. Install the M12 x 35mm captive bolt through the chassis access hole.
4. Push the captive bolt down through the bottom forward chassis hole.

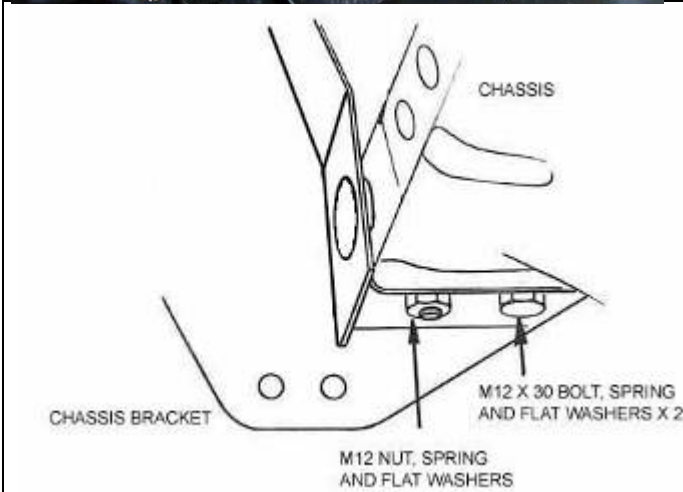

5. Fit the chassis brackets against the front crossmember and under chassis rails with captive bolt located through the front hole of chassis brackets.

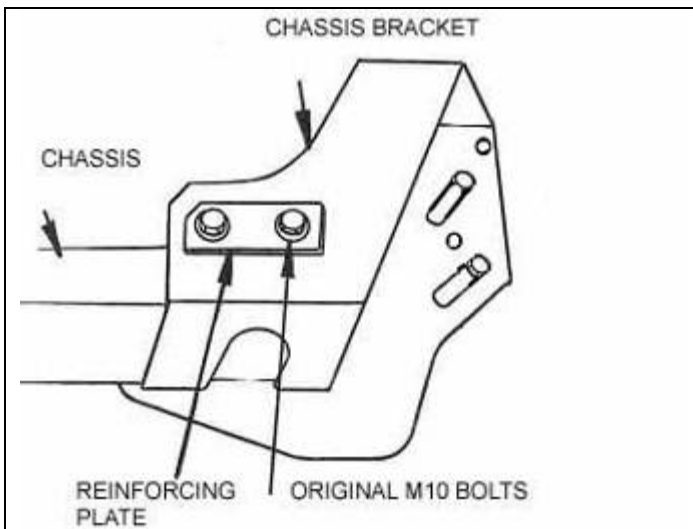

6. Fit four M12 x 30mm bolts, spring washers and flat washers (lower rear) and four M10 x 30mm bolts (original), flat washers and reinforcing plate (side mounts). Do not fully tighten yet.



2. When both chassis brackets are bolted finger tighten to chassis of vehicle, fit crash can to vehicle using 8mm hardware and heavy duty washer using same procedure as before. Finger tighten only.



3. When all bolts are fitted, adjust width of chassis brackets so there is an internal measurement of 752mm plus, so bull bar can fit in between chassis brackets.



4. At this stage, tighten all bolts, except outer 10mm original bumper bar bolts. Remeasure ID between chassis brackets.

DO NOT TIGHTEN THESE BOLTS AT THIS STAGE



5. Fit bull bar in between chassis brackets and secure using 2 x 10mm x 30mm bolts, flat washers etc. on each side. When bull bar is aligned to vehicle body, tighten all four bolts securely.

**DO NOT USE THESE HOLES
AIR BAG HOLES ONLY.**



6. Using a 10mm drill bit, drill hole using lower hole in chassis bracket as a template.



7. Bolt up using 10mm x 30mm bolts, flat washers, spring washers and nuts.

THIS IS THE PINNING BOLT FOR NON AIR BAG VEHICLES ONLY.

UNDER NO CIRCUMSTANCE PIN AN AIR BAG BAR



8. Tighten the outer original bumper bar bolts firmly

9. Bolt tow hook to chassis brackets.



10. Cable tie the inner guard plastic trims to the body of vehicle.



11. If fitting driving lights, secure using a ratchet, extension bar and socket through lower cutout in center of bar.



12. Hilift jacking is carried out using lower cutouts in center of bar