



FITTING INSTRUCTIONS

Part Number: **3432220**
Product **DISCOVERY 4 SUMMIT BULLBAR**
Description:
Suited to **LAND ROVER DISCOVERY 4 2014 ON FACELIFT**
vehicle/s: **3500590 Fog Light Kit (LH&RH Lights)**
Optional **3500640 - ARB AUX Fog Light Adaptor (low power OE fog lights)**
3500850 – ARB Summit RFL Cover
Fitting Kits: **3500680 Fog Lamp Housing Clear Lens Kit**
3500720 Winch Install Kit

WARNING

REGARDING VEHICLES EQUIPPED WITH SRS AIRBAG:

When installed in accordance with these instructions, the front protection bar does not affect operation of the SRS airbag.

ALSO, NOTE THE FOLLOWING:

- ◆ This product must be installed exactly as per these instructions using only the hardware supplied.
- ◆ In the event of damage to any bull bar component, contact your nearest authorised ARB stockist. Repairs or modifications to the impact absorption system must not be attempted.
- ◆ Do not use this product for any vehicle make or model, other than those specified by ARB.
- ◆ Do not remove labels from this bull bar.
- ◆ This product or its fixing must not be modified in any way.
- ◆ The installation of this product may require the use of specialized tools and/or techniques
- ◆ It is recommended that this product is only installed by trained personnel
- ◆ These instructions are correct as at the publication date. ARB Corporation Ltd. cannot be held responsible for the impact of any changes subsequently made by the vehicle manufacturer
- ◆ During installation, it is the duty of the installer to check correct operation/clearances of all components
- ◆ Work safely at all times
- ◆ Unless otherwise instructed, tighten fasteners to specified torque

ARB 4x4 ACCESSORIES

Corporate Head Office

42-44 Garden St
Kilsyth, Victoria
AUSTRALIA 3137

Tel: +61 (3) 9761 6622
Fax: +61 (3) 9761 6807

Australian enquiries
North & South American enquiries
Other international enquiries

sales@arb.com.au
sales@arbusa.com
exports@arb.com.au

www.arb.com.au

GENERAL CARE AND MAINTENANCE

By choosing an ARB Bar, you have bought a product that is one of the most sought after 4WD products in the world. Your bar is a properly engineered, reliable, quality accessory that represents excellent value. To keep your bar in original condition it is important to care and maintain it following these recommendations:



- Prior to exposure to the weather your bar should be treated to a Carnuba based polish on all exposed surfaces. It is recommended that this is performed on a six monthly basis or following exposure to salt, mud, sand or other contaminants.
- As part of any Pre Trip Preparation, or on an annual basis, it is recommended that a thorough visual inspection of the bar is carried out, making sure that all bolts and other components are torqued to the correct specification. Also check that all wiring sheaths, connectors, and fittings are free of damage. Replace any components as necessary. This service can be performed by your local authorized ARB Stockist.

FITTING REQUIREMENTS

REQUIRED TOOLS FOR FITMENT OF PRODUCT:

POWER DRILL	SCREWDRIVER SET
METRIC SOCKETS AND SPANNERS	TORX BIT SET
UTILITY KNIFE	MARKER PEN
TORQUE WRENCH (9- 102Nm)	MASKING TAPE
Ø6 & Ø11mm DRILL BITS	JIG SAW OR MULTI-TOOL WITH BLADE SUITABLE FOR PLASTIC
HALF ROUND FILE	

HAVE AVAILABLE THESE SAFETY ITEMS WHEN FITTING PRODUCT:

Protective eyewear		Hearing protection	
--------------------	---	--------------------	---

NOTE: 'WARNING' notes in the fitting procedure relate to OHS situations, where to avoid a potentially hazardous situation it is suggested that protective safety gear be worn or a safe work procedure be employed. If these notes and warnings are not heeded, injury may result.

FASTENER TORQUE SETTINGS:

SIZE	Torque Nm	Torque lbft
M6	9Nm	7lbft
M8	22Nm	16lbft
M10	44Nm	32lbft
M12	77Nm	57lbft

USE	PART no	QTY	DESCRIPTION
FIT MOUNTS TO CHASSIS	3759932L	1	MOUNT ASSEMBLY DISCO UPGRADE
	3759932R	1	MOUNT ASSEMBLY DISCO UPGRADE
	3194887	2	PLATE NUT ASM
	6151638	4	BOLT HXHD M10x1.5x40
	4581040	4	WASHER FLAT M10x25x3
	4581048	4	WASHER SPRING M10x1/8x1/8
FIT BAR TO MOUNTS	6151360	6	BOLT M12 x 1.75 35mm Gd 8.8
	6151428	6	NUT FLANGE M12 x 1.75 ZP
	4581007	6	WASHER FLAT 1/2 x 1.1/2 x 4MM TZP
	4581050	6	WASHER SPRING M12 ZP
	6151357	4	BOLT SEMS M10 x 1.5 x 30mm Gd 8.8
FIT LIGHTS AND MOULDINGS	6151321	4	NUT FLANGE M10 x 1.5 ZP
	3500880	1	GRILLE SPLIT PAN KIT
	5100200	1	BUFF KIT 2PCE FRONT SECTION KIT
	5100210	1	BUFF KIT 2PCE REAR UPRIGHT BAR KIT
	6821287	1	LAMP LED INDICATOR CLEARANCE KIT
	3163082	1	SURROUND ARB FOGLIGHT KIT
	6821116	4	GROMMET NYLON SNAP IN TYPE
FIT LICENCE PLATE	5848428	4	SHIM OVER RIDER 1.6MM
	3759488	1	BRACKET REG PLATE FIXED LARGE RAD
	6151384	2	SCREW ST PHDCOL PH 5.2 X 16 TBZP480
	6821189	2	GROMMET RND FC 1500 080 090
	6151213	3	BOLT M6x1.0x20 8.8 BZ
	4581287	3	WASHER SPRING M6 x 2.5 x 1.6 BLK ZN
WASHER BOTTLE SUPPORT TO IMPACT ABSORBERS	4584295	3	WASHER FLAT M6 x 12 x 1.3 BLK ZN
	6151128	3	NUT FLANGE M6 x 1.0 ZP
	3756801	2	WASHER BOTTLE SUPPORT BRACKET
	6151301	4	CAGE NUT M8
	6151021	4	BOLT M8 x 20mm HEX HEAD
	4581044	4	WASHER FLAT M8
STONE TRAY & FAIRLEAD COVER TO BULL BAR	4581046	4	WASHER SPRING M8
	6151300	2	CAGE NUT M6
	6523101	1	PANEL STONE GUARD
	6523102R	1	PANEL WING RH
	6523102L	1	PANEL WING
	6151315	10	CAGE NUT M6
	6151711	10	SCREW BTN HD TX M6X25 BTZP480
FIT WINCH COVER PANEL	4581082	10	WASHER FLAT M6 x 20 BLACK ZINC
	4581287	10	WASHER SPRING M6 BLACK ZINC
	6523063	1	PRESS FORM WINCH COVER PANEL
	6151213	4	BOLT M6x1.0x20 8.8 BZ
	4581287	4	WASHER SPRING M6 x 2.5 x 1.6 BLK ZN
FIT WINCH COVER PANEL	4584295	4	WASHER FLAT M6 X 12 X 1.3 BLK ZN
	6151128	4	NUT FLANGE M6 x 1.0 ZP

MISCELLANEOUS	180302	14	CABLE TIES
	3163091	4	PLUG BLANKING – PARKING SENSOR
	6191035	2	EXTRUSION PINCH WELD
	6250030	2	SPACER-WASER NOZZLE
	3789570	1	TEMPLATE-WHEEL ARCH FLARE
PARKING SENSORS	665044	1	3M PRIMER STICK
	3759843	4	BRACKET PARK SENSOR
	6781427	4	BUTYL PATCH
	6781437	1	TAPE 3M - 2.3MM VHB 20X25 8PCS
	160253	4	O-RING

VEHICLE PREPARATION



Note: Read the instructions thoroughly before starting.

1. Remove Grille from vehicle.
4 clips along top face of grille and 2 clips behind centre grill.
Store grille in safe place for re-fitment later



2. Unclip and remove the Headlights from the vehicle.

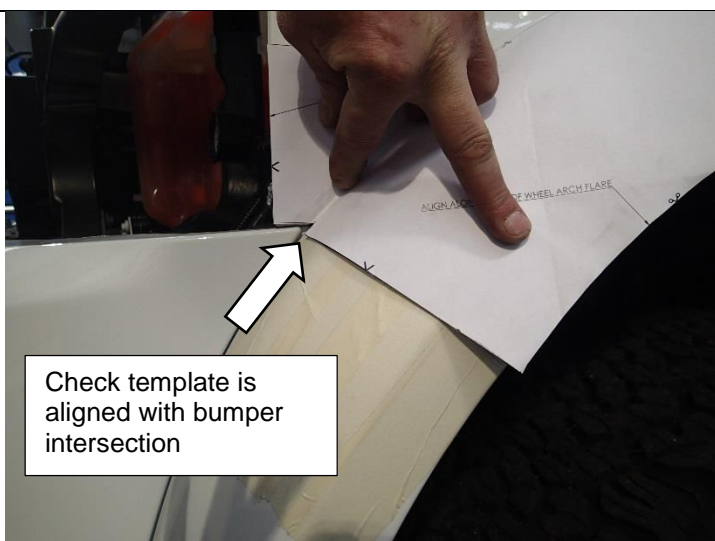

Check template is aligned with bumper intersection

3. Place masking tape on both LH and RH Fender Flares, approx. 100 mm either side of headlight fender intersection
4. Carefully cut out both bumper cut templates supplied.
Note: Check Scale of drawing
5. Position Template 3789570 onto LH Fender Flare aligning with edges of Fender specified on template.
6. Using a permanent marker, mark along edges of the template onto masking tape where the cut will be performed.
7. Remove template and repeat the above for LHS. Take care not to rip template upon removal.

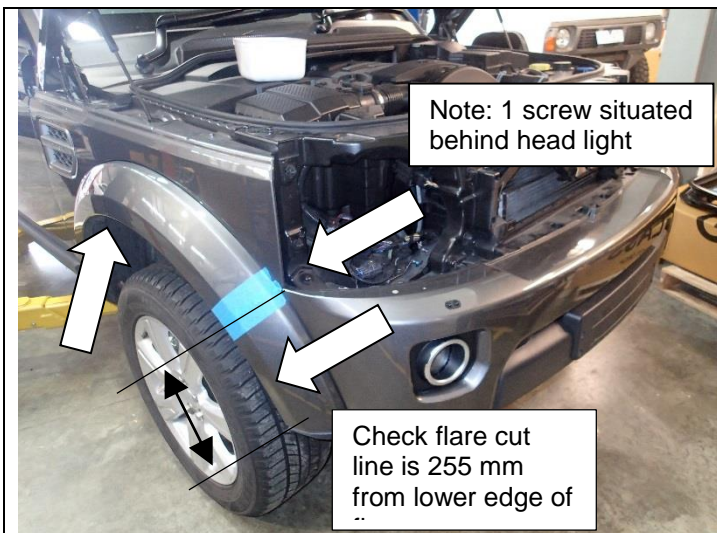

8. Remove scrivet and screws that attach the wheel arch flare at the front.
9. Pull the front of the flare away from the vehicle and cut the flare where marked.

Note: Ensure body panels are protected while cutting wheel arch flare



Warning: Cutting operations can result in flying metal debris, safety glasses and hearing protection should be worn.

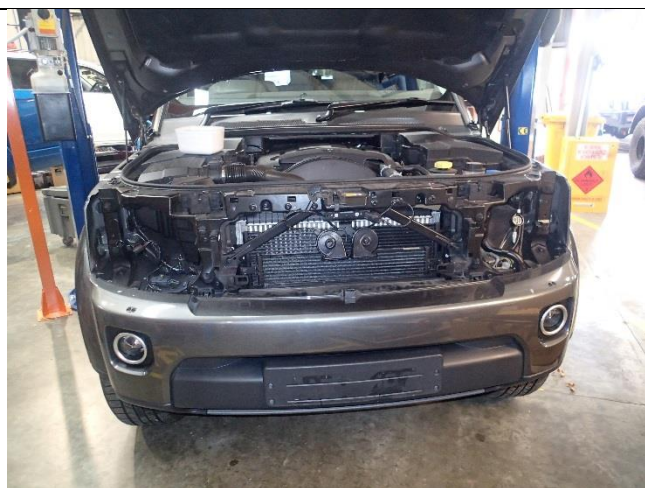

10. Remove all fasteners and scrivets retaining bumper. Disconnect harness from LH side of vehicle and washer nozzle hoses from RH side and remove bumper assembly from vehicle

NOTE: Be prepared to block or clamp off the washer bottles lines to prevent water leaking on the ground.

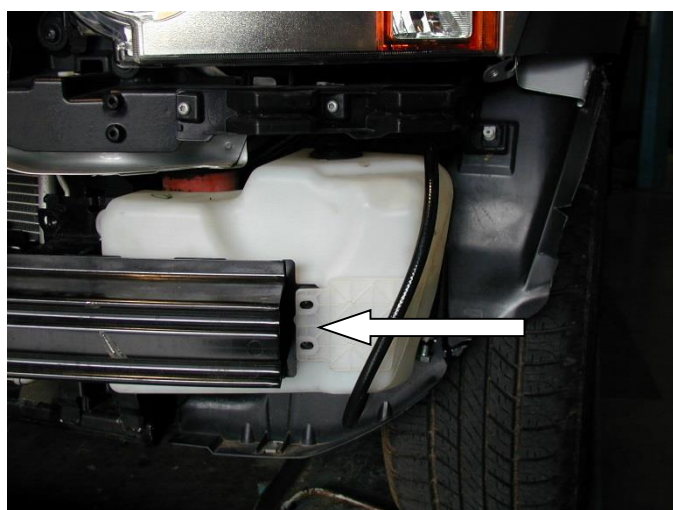

11. Remove the two bolts attaching the bumper cross bar to the washer bottle.

Set aside for re-fitment later on.

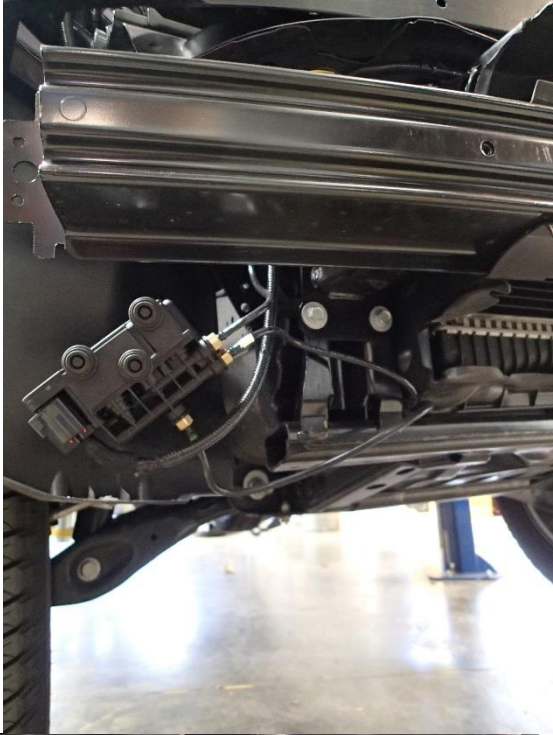

12. On air suspension models, remove the solenoid pack attached to the right hand side of the impact beam.
13. Remove 8 x M8 Bolts that hold the impact beam and removed beam from the vehicle.

Set aside bolts for re-fitment later on.



14. Cut the air inlet duct where marked.

Note: Ensure body panels and wiring are removed and protected while cutting.



Warning: Cutting operations can result in flying metal debris, safety glasses and hearing protection should be worn.

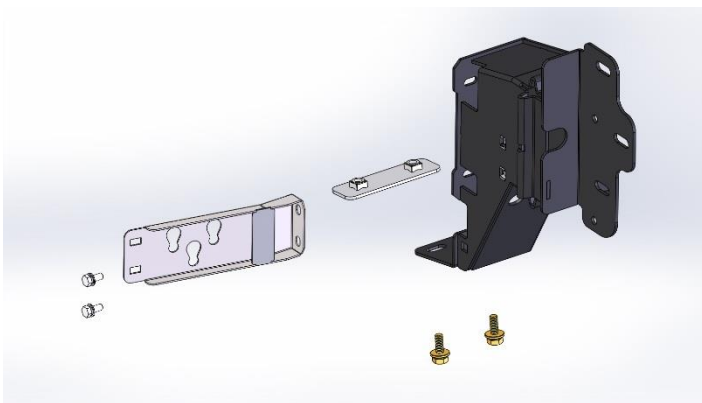

16. Fit the 2 x M8 cage nuts to the impact absorbers. (RH shown, LH symmetrically opposite)

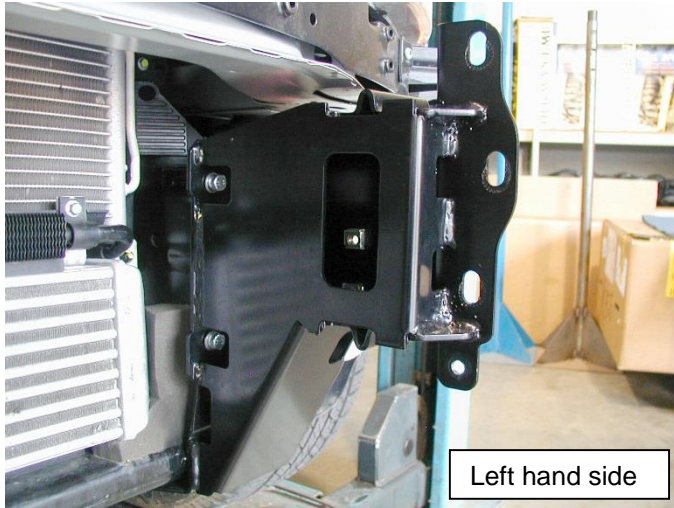

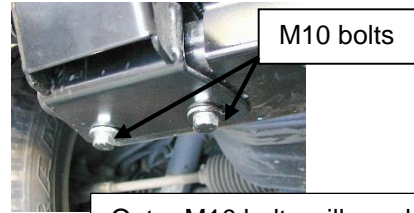

17. Mount both the Mount Assembly impact absorbers to the vehicle using 8 x M8 bolts that came from the vehicle 4 per side and 2 X M10X40 HEX BOLT, 2 x M10x25x3 Flat washer and 2 x M10 Spring washer AND 2 X Nut plate assemblies in the lower impact beam. (DO NOT TIGHTEN)

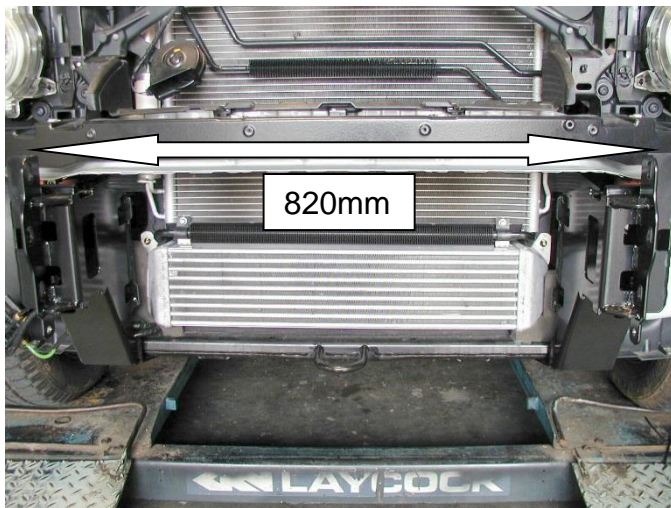

Outer M10 bolts will need to be removed for wing panel fitment



18. Centralise the mounts so that the surface that mounts to the bull bar is vertical and plumb.
19. The mounts must be positioned so that they are equally spaced from the centre of the vehicle and there is an 820mm gap between the outside surfaces of the bull bar mounting face.
20. Tighten all the bolts.

-  M8 – 22 Nm
-  M10 – 44 Nm

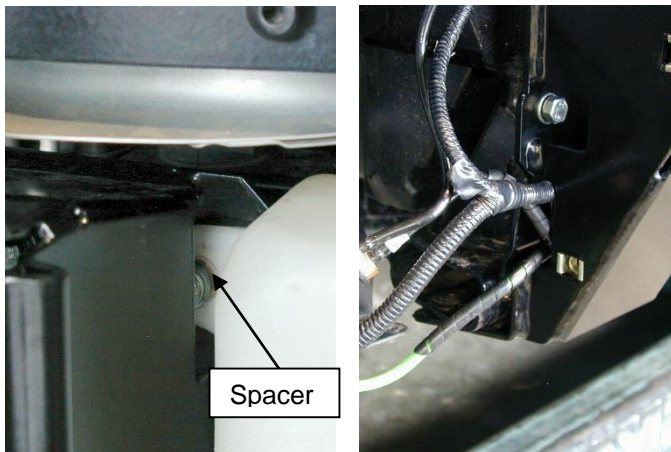

21. On the left hand side, the washer bottle sits in front of the mount face. Use longer existing M8 bolt and check that the metal spacer in the washer bottle tag remains in place.
22. On the right hand side, the air lines on air suspension models run through the gap in the impact absorber backing plate.

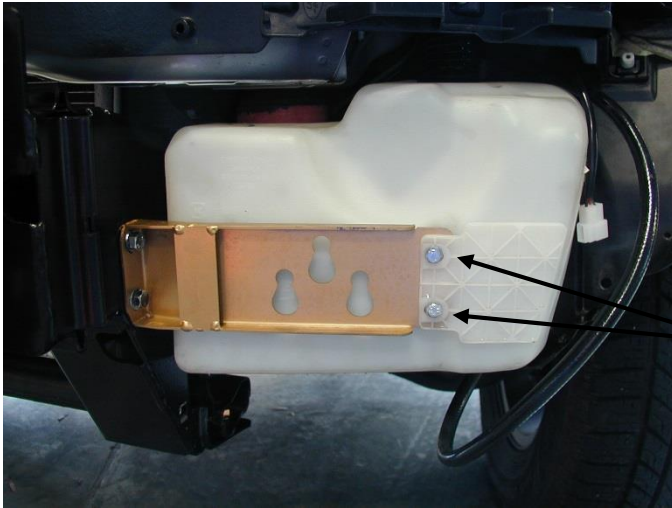

23. Install 2 x M6 cage nuts into one of the Washer bottle support brackets.
24. Attach the washer bottle support bracket with the cage nuts installed to the left hand side impact absorber using two M8 x 20mm bolts, M8 flat and spring washers.
25. Fix the washer bottle to the bracket re-using 2 x M6 bolts that came off the vehicle.

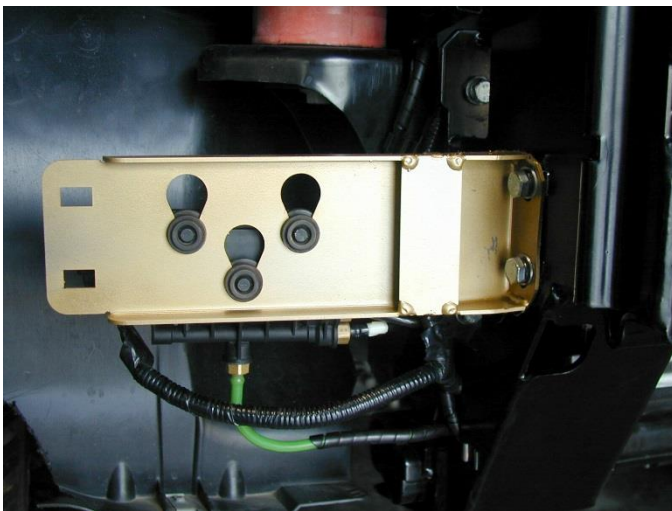

26. Attach the other washer bottle support bracket without cage nuts to the right hand side impact absorber, using two M8 x 20mm bolts, M8 flat and spring washers.
27. On vehicles equipped with air suspension, attach the solenoid pack to the bracket.

IMAGE OF HEAD LIGHT CONNECTOR PIN POSITIONS FOR BOTH LH AND RH SIDE

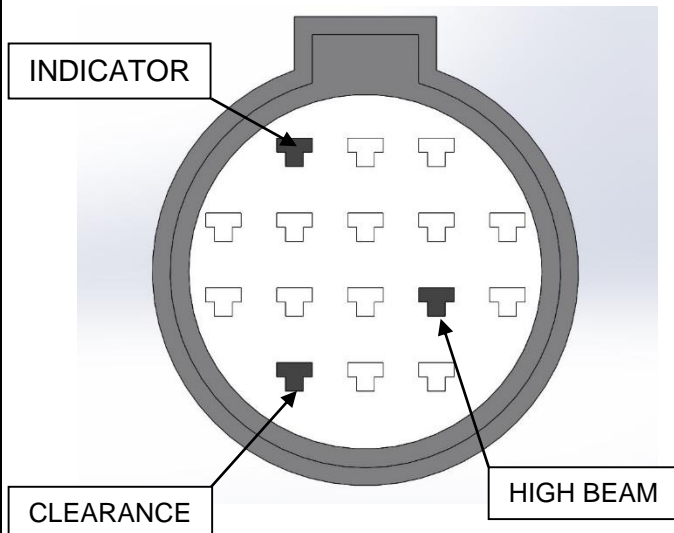

28. Following fitting instructions 3789197 supplied in kit 6821287; attach the LED combination lamp looms (also supplied in same kit). Vehicle coloured wires can be found in the positions indicated.

Notes:

-Use solder to connect the joints.

-Cover each joint with either insulation tape or heat shrink tube.

- Use cable ties to secure all wiring.

Function	LED Wire	Vehicle Wire
Ground	Black	Black (RHS & LHS)
Indicator	Green	Green/White (RHS) Green/Red (LHS)
Clearance	Red	Red RHS Red/Black LHS
High Beam		Blue/Green LHS



29. Reassemble headlights, grille and wheel arch flare to the vehicle.
Vehicle should look like picture on left ready for Bull bar fitment.



30. While holding the Wheel arch flare and liner together drill a 6mm hole through both, 20mm above cut line
31. Remove screw boss from discarded lower dressing piece and refit to the wheel house liner.
32. Apply bumper trim pinch weld to both RH and LH sides along the full length of the cut edge. Carefully trim off any excess length.





33. Unclip both LH and RH washer nozzles and washer hose from bumper facia. Keep clips for refit to bull bar



34. Remove wiring harness from Bumper bar and if fitted 4 x parking sensors.

FITTING PROCEDURE

Note: If fitting a winch proceed using fitting instructions 3789337 supplied with 3500720 winch install kit. Once the winch is fitted please continue to step 38. If no winch is being fitted continue from step 35.

35. Slide the winch cover panel from the bottom up until it is level with the top face of the bar.

36. Fit the winch cover panel to the bar using 4 x M6 x 20 hex bolts, spring washers, flat washers and flange nuts.

Warning: Be careful not to scratch the finish of the winch cover panel.

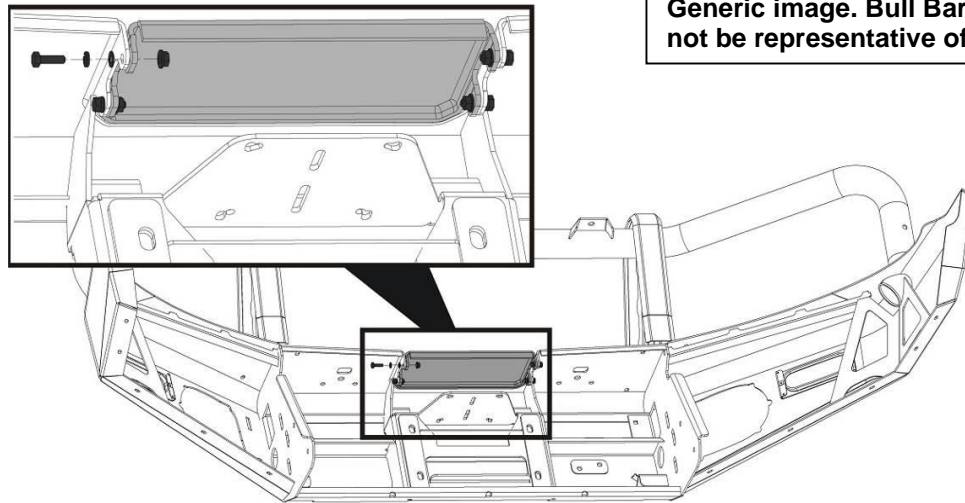

Generic image. Bull Bar shown may not be representative of actual product.

37. Fit the number plate bracket to the top face of the lower-centre pan on the bar using 3 x M6 x 20 hex bolts, spring washers, flat washers and flange nuts.

Note: If you are fitting a winch, fit the folding number plate bracket supplied in winch install kit "3500720 WINCH INSTALL KIT" – See fitting instructions 3789337

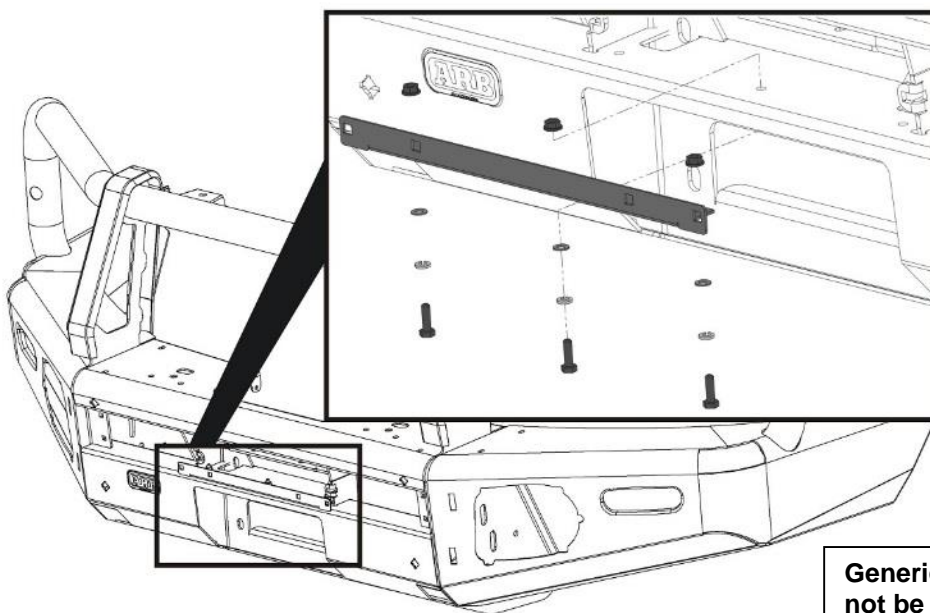

Generic image. Bull Bar shown may not be representative of actual product.

Note: The following steps show the fitment of the plastic moulded parts. The mouldings are supplied in kits along with all fasteners required for fitment. It is important that the fasteners supplied with each kit are only used for the mouldings from the same kit. The kits included in this bar kit are as follows:

38. Layout the contents of each of the following kits ensuring the contents are kept separate from each other.

Kit No.	Description
5100200	BUFF KIT 2PCE FRONT SECTION
5100210	BUFF KIT 2PCE REAR UPRIGHT BAR
3500880	SPLIT PAN MESH KIT
3163082	FOG SURROUND KIT

39. Mark the grille panel to be cut at the 800mm marks at each end on the back face.

Note: When marked, double check the measurement with a measuring tool.

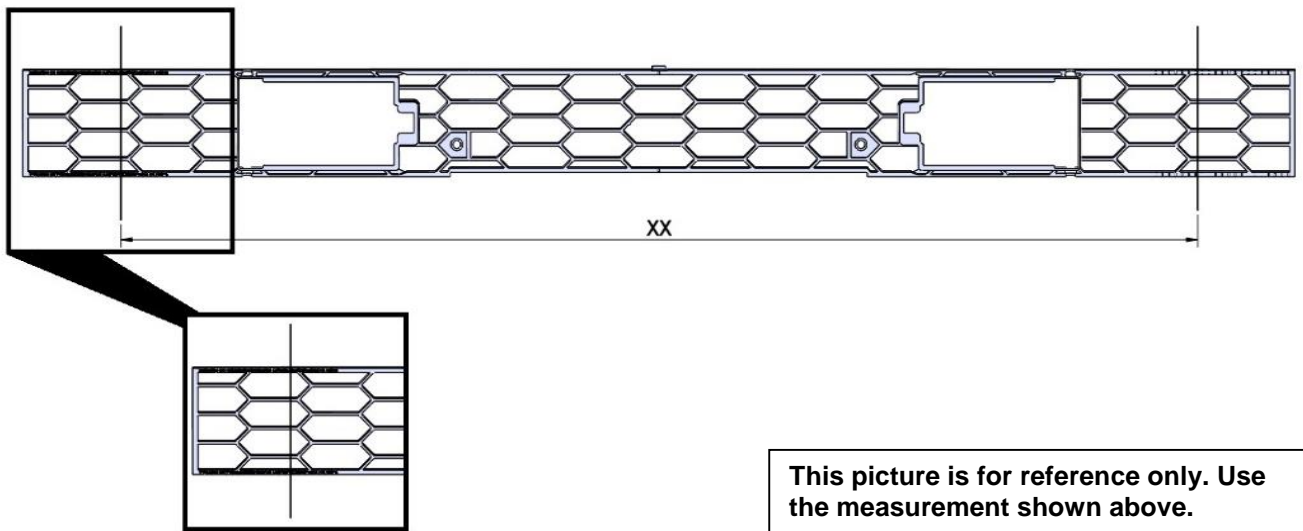

40. Use a hacksaw or similar cutting tool to carefully cut the grille panel at the positions marked in the step above.
 41. Discard the off cuts and clean up the cut edges using a file or sandpaper.

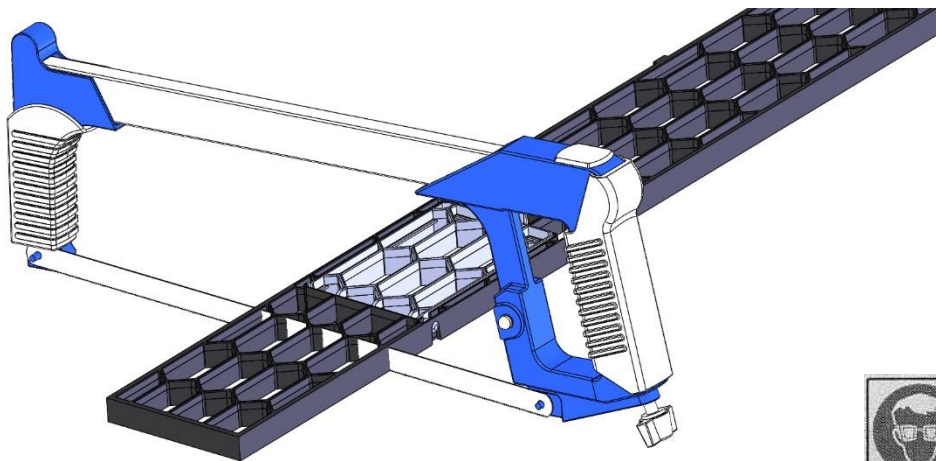

42. Insert the 6 x plastic grommets into the 6 square holes in the front face of the bar.
43. Insert the grille into the bar so that the hatches open outward (facing the front of the bar).
44. Attach the grille to the centre of the bar using the short screws into the grommets fitted above.
45. Attach the ends of the grille to the bar using the longer screws, through the clamp plates into the remaining grommets.

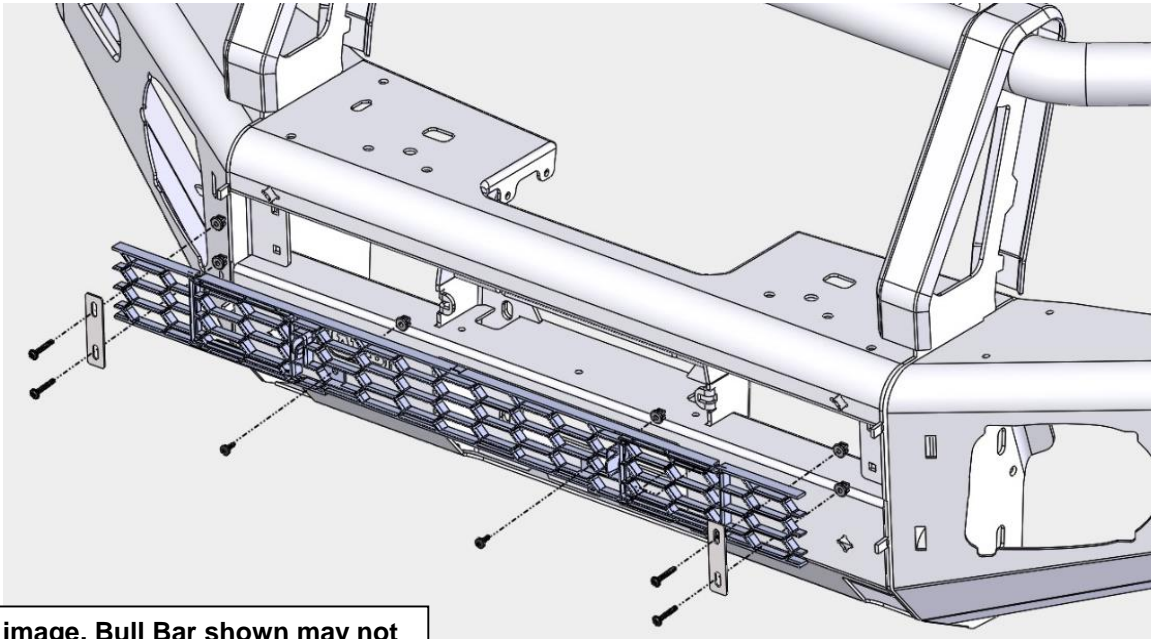

Generic image. Bull Bar shown may not be representative of actual product.

46. Fit the rubber intersection mouldings to the base of each upright cover strap.

Generic image. Bull Bar shown may not be representative of actual product.

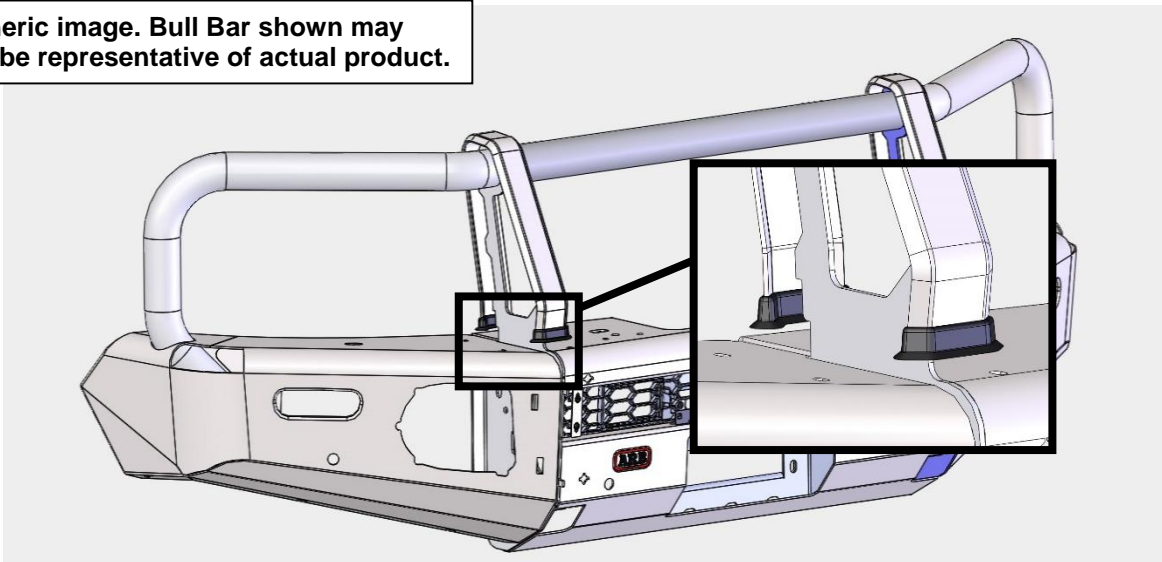

47. From the rear of the bar, slide the rear buffer sections under the rubber mouldings.

Fit 4 x screws and washers. Do not tighten screws. Leave enough play in buffers for adjustment later.

Note: Ensure that the skirts of the rubber intersection mouldings are not folded back on themselves and are sitting flat against the buffers.

Generic image. Bull Bar shown may not be representative of actual product.

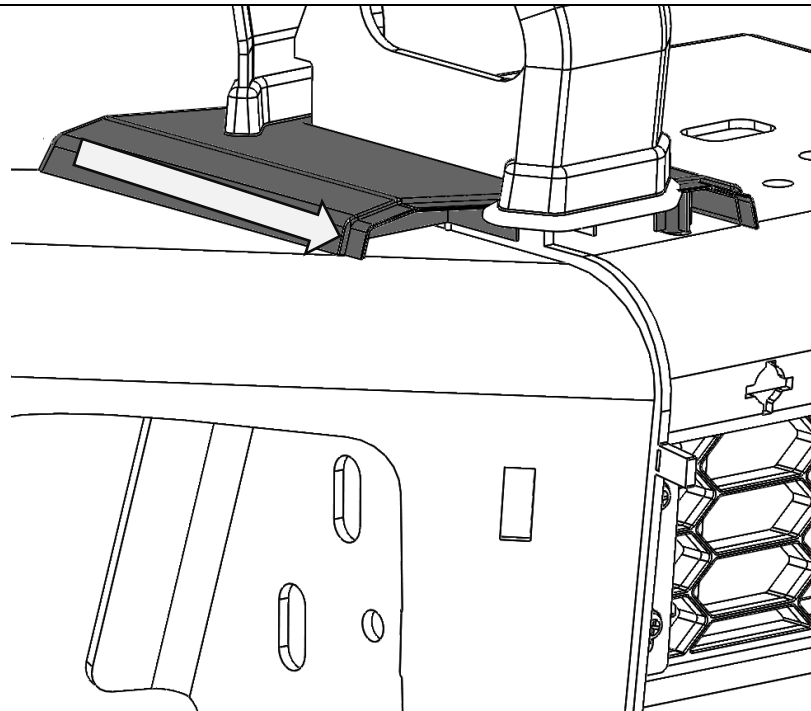

Fit washers under screw heads

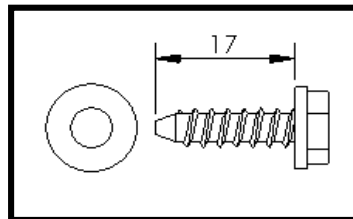

48. By aligning the front buffer with the tongue of the rear buffer, attach the front buffers to the front face of the bar. Ensure each buffer sits flat against the face of bar and is keyed into the top section of the rear buffer.

Secure wing side using retaining clips.

Secure inner side using the angled cup washers, flat washers and screws.

The widest point of the cup washers goes to the top of the bar.

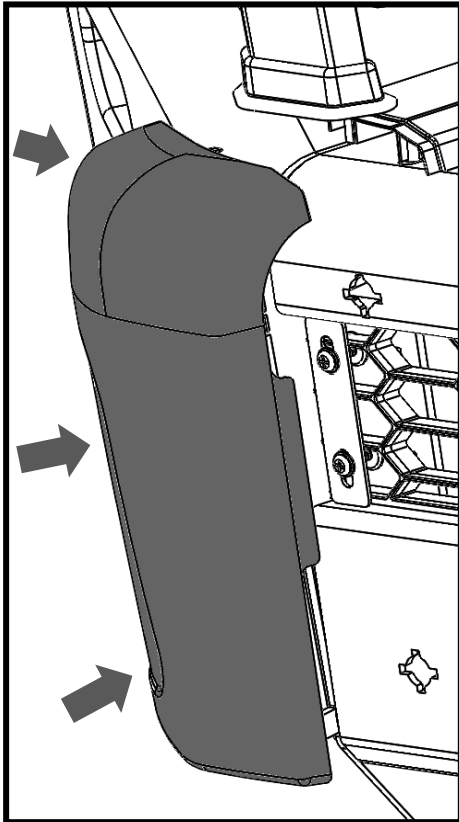

Generic image.
Bull Bar shown
may not be
representative of
actual product.

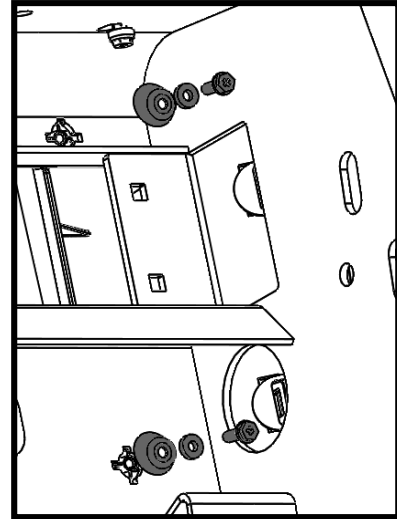

Fit washers under screw heads.

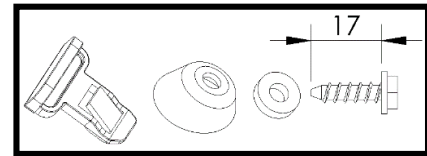

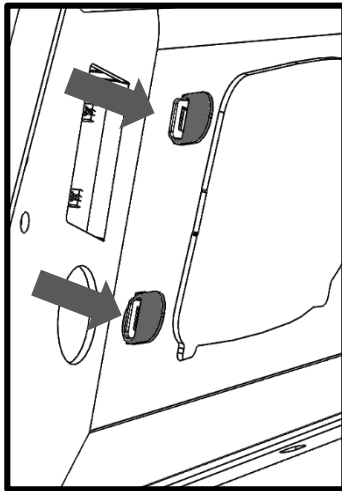
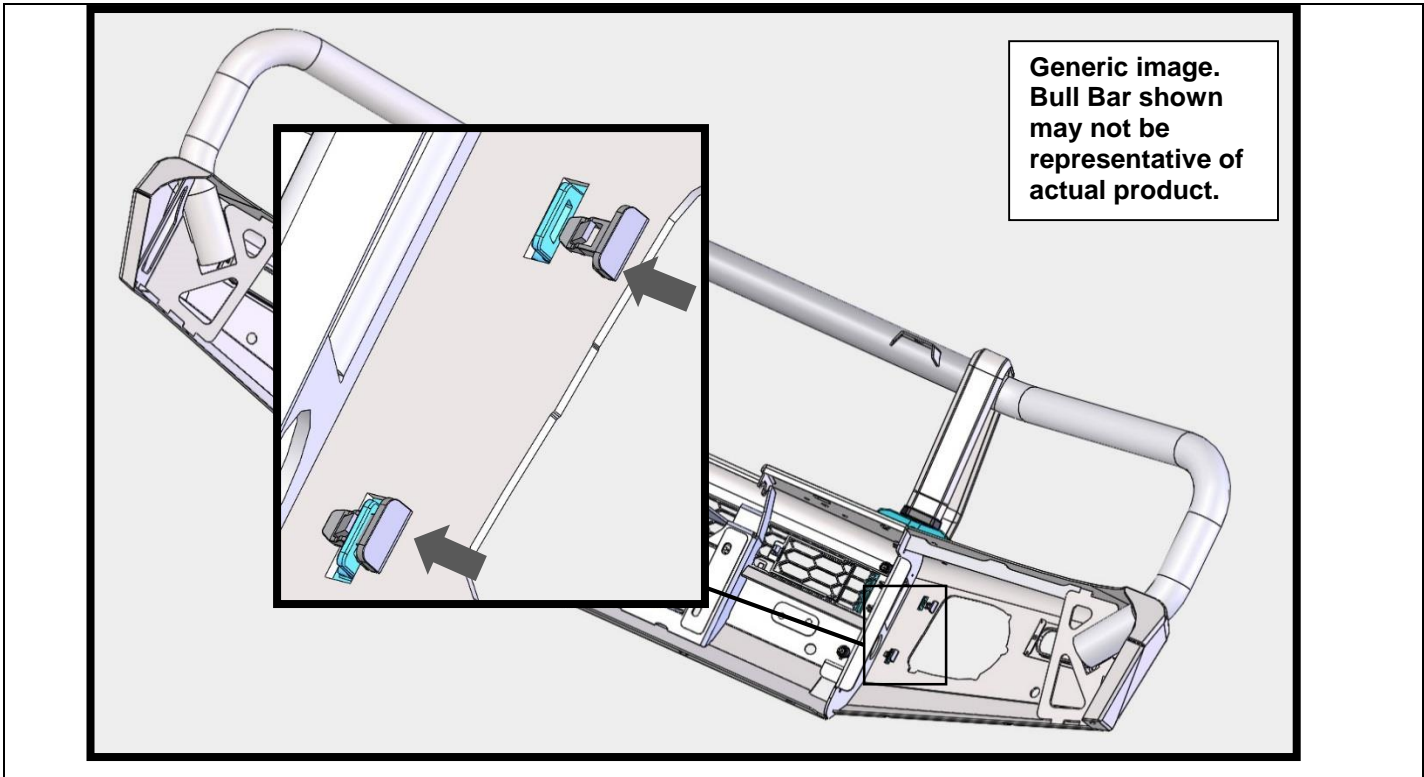

**Fit 5848428 shims
over tabs.
Note: If clips are too
tight to engage,
shims may be
removed to reduce
tension**

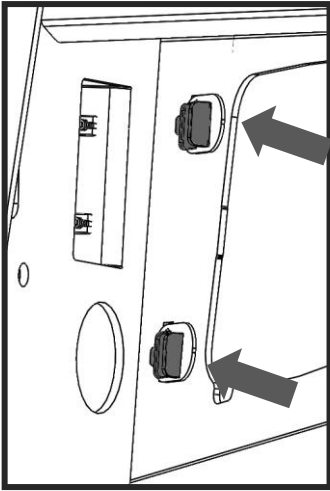

**Slide retaining clips
through tabs to lock
buffer in place**

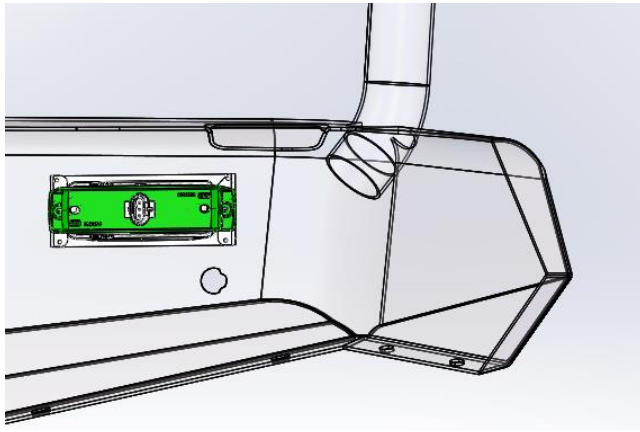

49. Fit the small plastic grommets to the bar and attach the combination LED lamps to the bar using the screws provided with the lamp kit. Details provided in Fitting instruction 3789197.

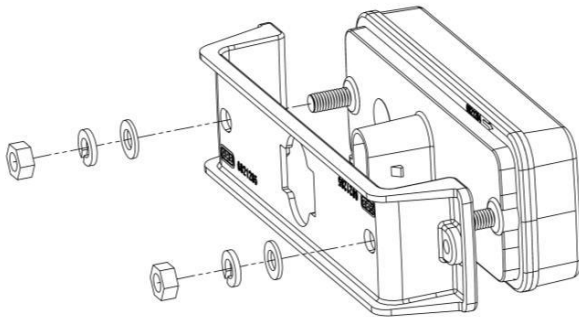

50. Install 6821285 bracket onto LED lamp with 2 x flat washers, 2 x spring washers and 2 x M6 nuts as shown. Note: Bracket and fasteners are supplied in 6821287- LED Indicator/Clearance Kit.

Torque to specification.



M6 - 3 Nm.

NOTE: Do not over-tighten.

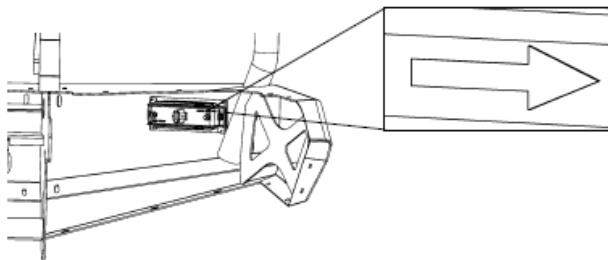

51. Install LED lamp with bracket into bull-bar using 2 x 15mm mounting screws provided in 6821287 - LED Indicator/Clearance Kit. (RH Shown).

Note: Do not fully tighten.

IMPORTANT: The clearance LEDs must be on the outboard edge of the bull-bar. To achieve this, position lamp with arrows facing outside of vehicle as shown below.



CAUTION: Cable-tie all cables together and keep all cables clear of sharp edges and all moving parts.

52. Check fitment of combination light surrounds (P/N 3163082) as per instructions no. 3789190 supplied with surround kit.

Note: Optional fog lamps can be installed at this point as per fitting instruction supplied with fog lamp kit no. 3500590

Note: OE fog lights are 50W, therefore relay adapter loom 3500640 is required to supply the higher power ARB 55W fog lights.

53. Check the operation of all lights wired during bar fitment



54. Route hoses and harness thru bull bar cable tie where required.

55. Fit Spacer-Washer Nozzle between nozzle and carry over clip when fitting washer hoses

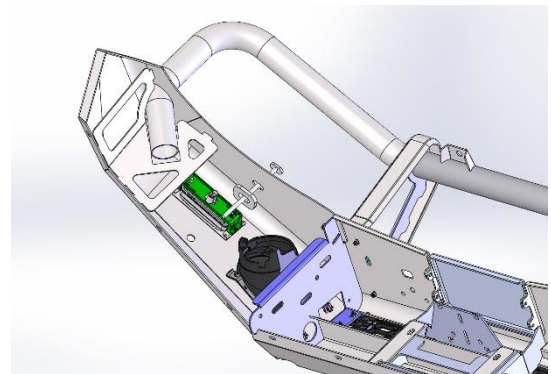

Parking Sensor Fitment (If option is present on vehicle). If not fitting parking sensors, go to step 63.

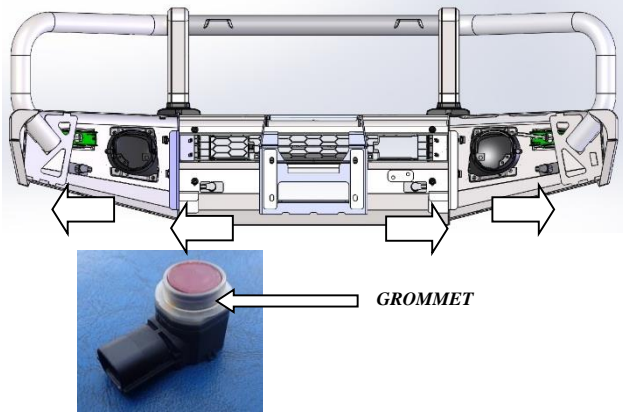

HINT: Mark sensors and loom to ensure sensors are installed back to the same location.

56. Carefully remove the parking sensors from the loom ensuring you have all of the clear rubber grommets that fit between the sensors and the bumper holes.

Note: When fitting parking sensors to the bar it is important that they are installed in the correct orientation. The arrows to the left show the direction the plug end of the sensors should face.

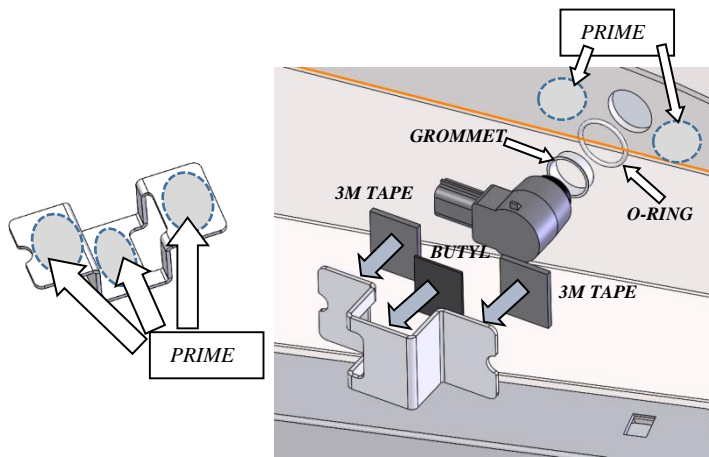

For each parking sensor: Ensure both the parking sensor bracket and mating area of the bull bar are thoroughly cleaned with Scotch Brite, soap and water and surfaces are completely dried off.

57. Using the priming pen supplied, prime the mating faces of both the bracket and the bar.

58. Remove the backing tape from one side of the double sided tape pads and apply to each of the mating faces of the bracket using the picture as an indication. Ensure the clear silicon grommet is fitted to the sensor.

59. Place the o-ring over the clear silicon grommet from the front of the sensor.

60. Ensuring the clear silicon grommet and o-ring remains in place on the end of the sensor. Remove the remaining Butyl tape backing. Carefully align the parking sensor into the hole in the bracket facing the correct direction. Firmly press the sensor onto the mounting bracket.

NOTE: Orientate loom connectors and bracket to point toward the centre of the vehicle.

61. Remove the remaining backing tape from the 3M tape pads and attach the bracket to the bar carefully aligning over the sensor as shown in the picture to the left.

NOTE: Ensure sensor is centred in bull bar hole as indicated in the picture to the left. Misalignment applying side pressure to the sensor may cause malfunction of sensor.

62. Apply pressure to the bracket for at least 60 seconds.

NOTE: Full adhesion is obtained after 72 hours.

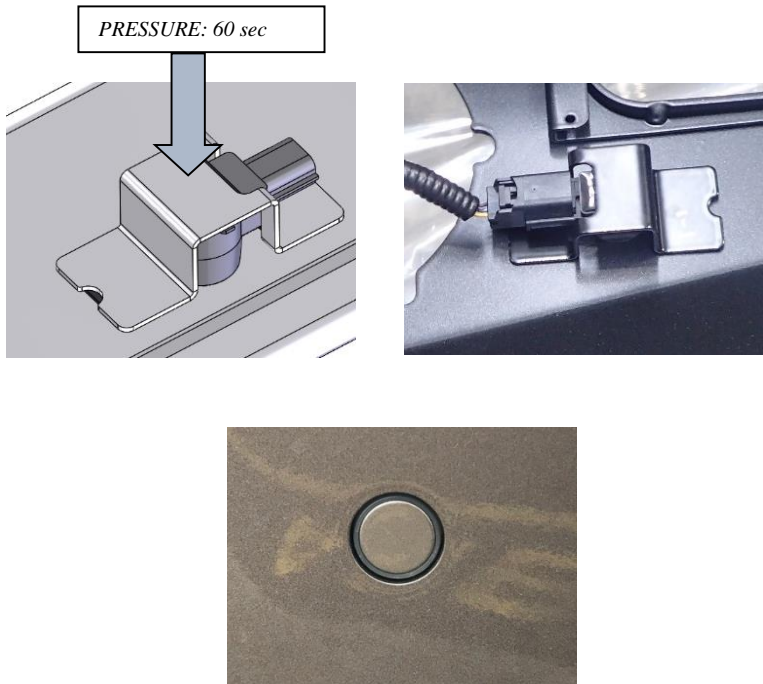

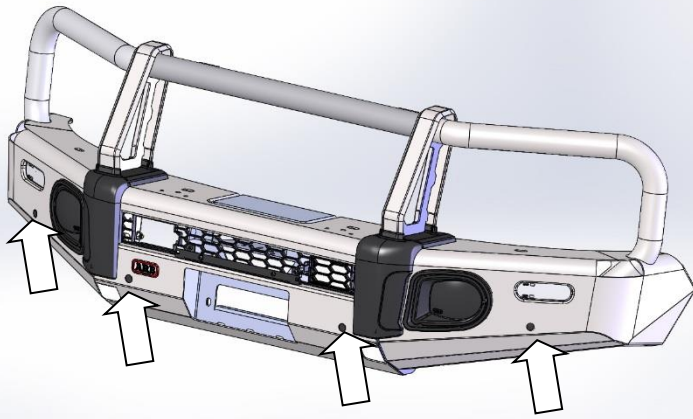

63. If parking sensors are not fitted install 4 x blanking plugs in parking sensor holes, as shown.

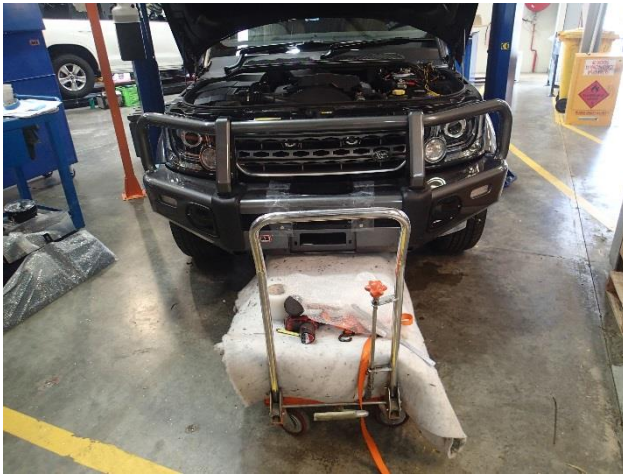

64. With the assistance of another person, place the bar on the mount brackets.

Warning: Due to the weight of the bar and winch if fitted, it is advised that you use some form of mechanical assistance when lifting the bar onto the vehicle such as an elevating trolley.

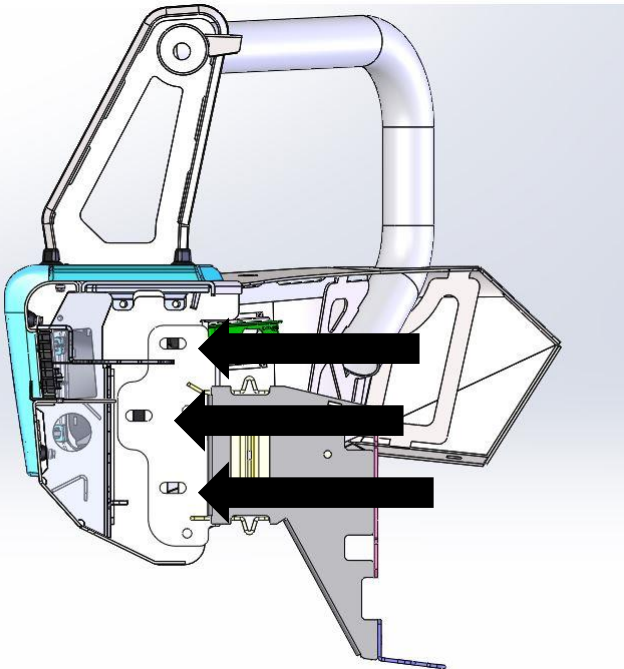

65. Loosely fasten bar to mounts using 6x M12x1.75x35mm bolts, 6x M12 spring washers, 6x M12 flat washers and 6X M12 flange nuts.

ARROWS INDICATE WHICH HOLES TO USE IN SECTION VIEW DRAWING.

SECTION VIEW IS RHS OF VEHICLE.



66. Adjust position of bar left/right until it's sitting central to body, then tighten all fasteners joining mount assembly to chassis brackets.

 M12 – 77Nm

 M10 – 44Nm



67. Align bull bar so there is a 10mm to 15mm gap from top pan to grille and an even 15mm minimum gap to head lights and wheel arch flare.

Note: Rear edge of bar may not be tangent to wheel arch.

68. Once bar is visually in correct position, tighten 6x M12 fasteners joining bull bar to mount assembly.

 M12 – 77Nm

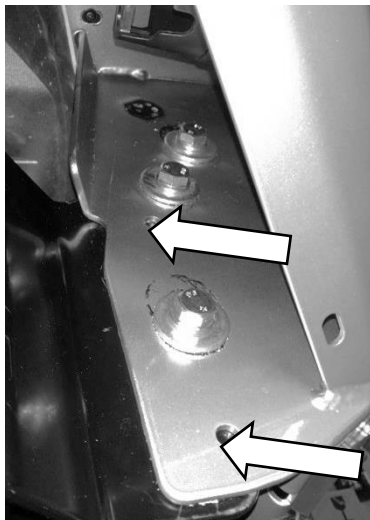

69. Drill 4x Ø11mm pinning holes (2 per side) through mount assembly using existing holes in bull bar as guide.

70. Add anti-corrosion touch up paint to area drilled.

71. Fasten 4x M10 SEMS bolts and flange nuts to pinning holes.

 M10 – 44Nm



Warning: Drilling operations can result in flying metal debris, safety glasses should be worn.



72. Install combination light surrounds (P/N 3163082) as per instructions no. 3789190 supplied with surround kit.

Note: Optional fog lamps can be installed at this point as per fitting instruction supplied with fog lamp kit no. 3500590

Note: OE fog lights are 50W, therefore relay adapter loom 3500640 is required to supply the higher power ARB 55W fog lights.

CAUTION: Cable-tie all cables together and keep all cables clear of sharp edges and all moving parts.

73. Check the operation of all lights wired during bar fitment

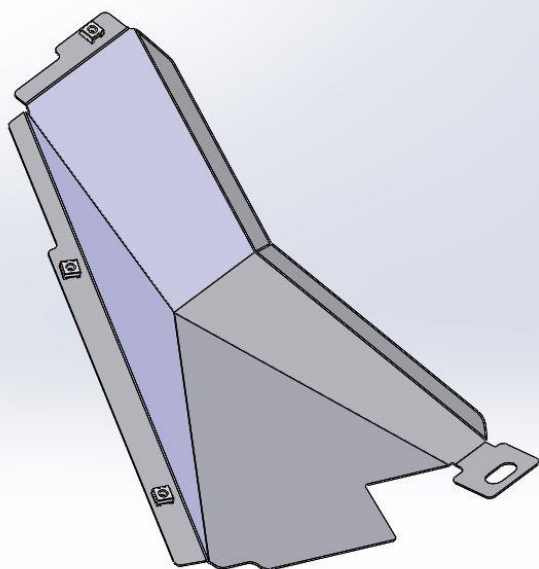

74. Fit 3 x M6 cage nuts to each wing under panel.

Note: Cage nut heads to be located on top side.

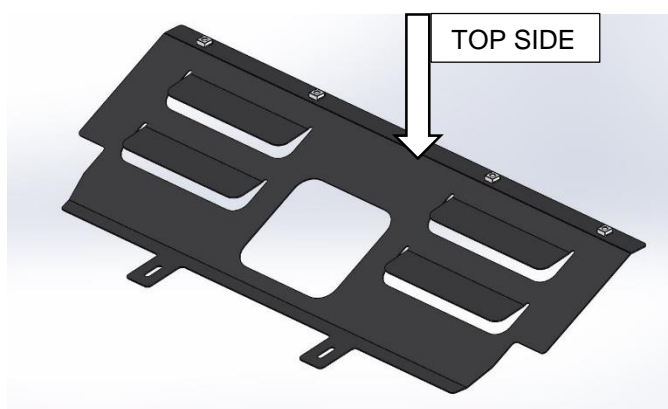
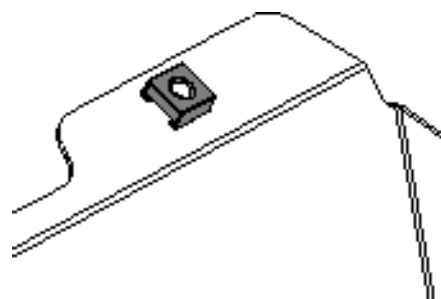

75. Fit 4x M6 cage nuts to Panel Stone Guard.

Note: Cage nut heads to be located on top side of stone guard.

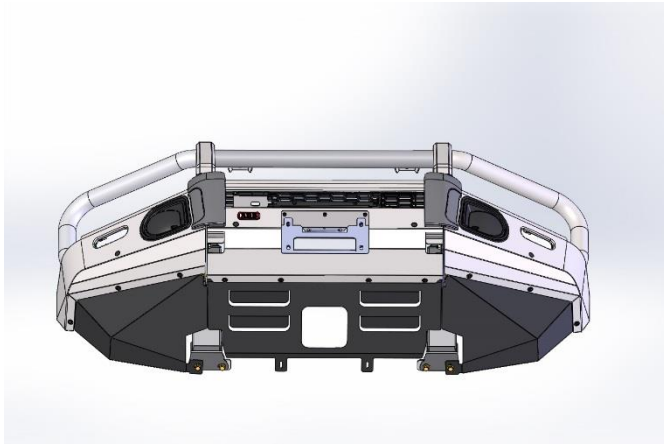

76. Fasten stone tray and wing under panels to bull bar using 10 x M6 button head screws, 10 x M6 spring washers, 10 x M6 flat washers, refit 2 x M6 bolts with 20 mm dia. captured washer from the vehicle and 2 x M10 SEMS Bolts

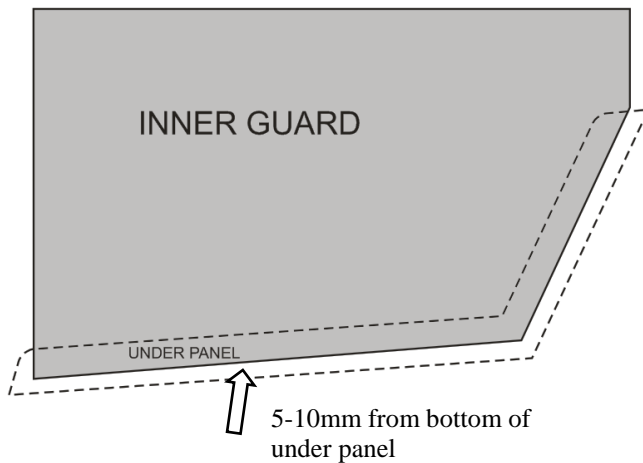

77. Mark lines onto the OEM inner guards (LH & RH) using wing under panels as guide ensuring enough guard remains so that it may be neatly tucked/secured behind wing under panel lip.

78. Carefully cut along marked lines using a multi tool or jig-saw.

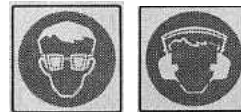

Warning: Cutting operations can result in flying metal debris, safety glasses should be worn.

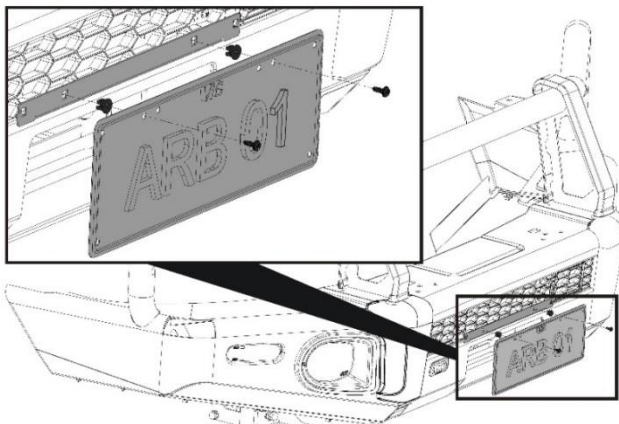

79. Fit the plastic plugs into the square holes in the licence plate bracket. Fit the licence plate to the bull bar using the black self-tapping screws.

80. Discard of all remaining fasteners left over.

ONCE BAR IS FITTED:

- Ensure all bolts are tensioned correctly.
- All wiring is clear of sharp edges or moving surfaces and secured properly.
- Piping is secured well away from sharp or moving components.
- Check operation of winch, if fitted.
- Check all wiring and connections to turn signal lamps, sensors, headlamp washers etc. are functioning correctly.
- Misalignment of parking sensor to hole in bull bar may cause malfunction, if fitted.
- Test operation of parking sensors after fitment, if fitted.

Note:

If parking sensors are fitted, do not add any accessories to the Bull Bar on or around the sensors, this may affect the function of the sensors.

Sensors may not function well under the following conditions;

- After the vehicle, has been sitting out in hot or cold weather.
- When the system is affected by electrical equipment or devices generating an ultrasonic wave.
- When operating in bad weather.

