



FITTING INSTRUCTIONS

Part Number: 3446320
Fitting Kit No. 6172350
Product Description: COMBINATION BULL BAR FLARED
Suited to vehicle/s: MITSUBISHI TRITON 2009 ON

WARNING

REGARDING VEHICLES EQUIPPED WITH SRS AIRBAG:

When installed in accordance with these instructions, the front protection bar does not affect operation of the SRS airbag.

ALSO, NOTE THE FOLLOWING:

- ◆ This product must be installed exactly as per these instructions using only the hardware supplied.
- ◆ In the event of damage to any bull bar component, contact your nearest authorised ARB stockist. Repairs or modifications to the impact absorption system must not be attempted.
- ◆ Do not use this product for any vehicle make or model, other than those specified by ARB.
- ◆ Do not remove labels from this bull bar.
- ◆ This product or its fixing must not be modified in any way.
- ◆ The installation of this product may require the use of specialized tools and/or techniques
- ◆ It is recommended that this product is only installed by trained personnel
- ◆ These instructions are correct as at the publication date. ARB Corporation Ltd. cannot be held responsible for the impact of any changes subsequently made by the vehicle manufacturer
- ◆ During installation, it is the duty of the installer to check correct operation/clearances of all components
- ◆ Work safely at all times
- ◆ Unless otherwise instructed, tighten fasteners to specified torque

ARB 4x4 ACCESSORIES

Corporate Head Office

42-44 Garden St
Kilsyth, Victoria
AUSTRALIA 3137

Tel: +61 (3) 9761 6622
Fax: +61 (3) 9761 6807

Australian enquiries
North & South American enquiries
Other international enquiries

sales@arb.com.au
sales@arbusa.com
exports@arb.com.au

www.arb.com.au

GENERAL CARE AND MAINTENANCE

By choosing an ARB Bar, you have bought a product that is one of the most sought after 4WD products in the world. Your bar is a properly engineered, reliable, quality accessory that represents excellent value. To keep your bar in original condition it is important to care and maintain it following these recommendations.

- Prior to exposure to the weather your bar should be treated to a Canuba based polish on all exposed surfaces. It is recommended that this is performed on a six monthly basis or following exposure to salt, mud, sand or other contaminants.
- As part of any Pre Trip Preparation, or on an annual basis, it is recommended that a thorough visual inspection of the bar is carried out, making sure that all bolts and other components are torqued to the correct specification. Also check that all wiring sheaths, connectors, and fittings are free of damage. Replace any components as necessary.
- Please contact local Authorised ARB Stockist if you would like to have this service carried out on your behalf.

HAVE AVAILABLE THESE SAFETY ITEMS WHEN FITTING PRODUCT:

BASIC TOOL KIT

JIG SAW OR KEY HOLE SAW

Protective eyewear



Hearing protection



NOTE: 'WARNING' notes in the fitting procedure relate to OHS situations, where to avoid a potentially hazardous situation it is suggested that protective safety gear be worn or a safe work procedure be employed. If these notes and warnings are not heeded, injury may result.

FASTENER TORQUE SETTINGS:

SIZE	Torque Nm	Torque lbft
M6	9Nm	7lbft
M8	22Nm	16lbft
M10	44Nm	32lbft
M12	77Nm	57lbft

OPTIONAL LIGHT SETS TO SUIT THIS PRODUCT:

ARB FOG LIGHT KIT SUIT 6821201

Up to IPF 900 SERIES FOG OR DRIVING LIGHT SETS

USE	PART No	QTY	DESCRIPTION
IMPACT ABSORBER MOUNTING SYSTEM	6151357	7	BOLT M10 x 1.5 x 30mm SEMS ASSY
	6151090	2	BOLT M10 X 1.25 X 50mm
	6151040	1	BOLT M10 X 1.25 X 30mm
	4581040	3	WASHER FLAT M10
	4581048	3	WASHER SPRING M10
	4584291	2	WASHER CLAMPING
	3758945	1	MOUNT ASSEMBLY
	5848329	2	PACKER LOCATING
	6151321	7	NUT M10 FLANGE
	6151021	2	BOLT M8 X 20mm
	4581044	2	WASHER FLAT M8
	4581046	2	WASHER SPRING M8
	6151132	2	NUT FLANGE M8
	3756929 L/R	2	BRKT REAR EXTENSION BRACE
BULL BAR TO IMPACT ABSORBERS	6151357	4	BOLT M10 x 30mm SEMS ASSY
	6151360	6	BOLT M12 X 1.75 X 35 COARSE PITCH
	4581007	6	WASHER FLAT M12 X 37 X 4
	4581050	6	WASHER SPRING M12
	6151428	6	NUT FLANGE M12
	6151321	4	NUT FLANGE M10 X 1.5
	3788074	1	TEMPLATE TO CUT FRONT BUMPER
	3194353	2	PACKER PLATE
CONTROL BOX BRACKET	6151021	2	BOLT M8 x 20mm
	4581044	2	WASHER FLAT M8
	3751564	1	CONTROL BOX BRACKET
	6151132	2	NUT FLANGE M8
NUMBER PLATE BRACKET	6151180	4	BOLT M6 x 20mm (BRACKET TO BAR)
	6151046	4	WASHER FLAT M6 x 13mm
	6151128	4	NUT FLANGE M6
	3751313	1	NUMBER PLATE BRACKET
	6151384	2	SCREW PAN HD (NON WINCH BAR)
	6821189	2	GROMMET RHS
INDICATORS TO BAR	3163015	1	COMBINATION LIGHT SURROUND KIT
	6821152	2	TURN SIGNAL / CLEARANCE LIGHT LOOM
	180701	6	SCOTCH LOK
	6821151L	1	TURN SIGNAL / CLEARANCE LIGHT
	6821151R	1	TURN SIGNAL / CLEARANCE LIGHT
BUFFERS	6151128	12	NUT FLANGE M6
	3162466 L/R	2	BUFFERS 260 X 230 UPRIGHT BAR
AIR DEFLECTOR	6522664	1	AIR DEFLECTOR
	6151262	3	BOLT M8 X 20mm BLACK
	6151301	3	NUT CAGED M8
	4581075	3	WASHER FLAT M8 x 20mm BLACK
	4581047	3	WASHER SPRING M8 BLACK
	6151213	4	BOLT M6 X 20MM BLACK
	4581082	4	WASHER FLAT M6
	4581287	4	WASHER SPRING M6
	6151300	4	NUT CAGED M6
	UNDER WING PANEL	6151213	8
4581082		8	WASHER FLAT M6 BLACK
4581287		8	WASHER SPRING M6 BLACK
6151300		8	NUT CAGED M6
6151301		4	NUT CAGED M8
6151262		4	BOLT M8 X 20MM BLACK
4581075		4	WASHER FLAT M8 BLACK
4581047		4	WASHER SPRING M8 BLACK
3758191		2	BRACKET ADJUSTABLE WING UNDER PANEL
6522843L		1	WING UNDER PANEL LHS
6522843R		1	WING UNDERPANEL RHS
MISCELLANEOUS	6191015	2	PLASTIC MOULDING 450MM
	BLB 600	1	BATTERY LEAD 600MM BLACK
WINCH FITMENT	180302	8	CABLE TIES
	6151073	2	BOLT 3/8" X 1 1/2"
	6151074	2	BOLT 3/8" X 1 3/4"
	4581040	4	WASHER FLAT M10
	EG50	2	GROMMET RUBBER
	BLB600	1	BATTERY LEAD 600MM BLACK

WINCH HOLE COVER PANEL (IF NOT FITTING WINCH)	6522886	1	WINCH HOLE COVER
	6151256	2	SCREW M6 BUTTON HEAD S/S
	6151128	2	NUT FLANGE M6
	4581304	2	WASHER M6 S/S
	6191006	1	RUBBER EXTRUSION WINCH COVER
OPTIONAL FOG LAMPS	6821201	1	FOG LAMP KIT

**ASSEMBLY SEQUENCE FOR BULL BAR INSTALLATION.
PLEASE READ AND UNDERSTAND FITTING INSTRUCTIONS BEFORE
ATTEMPTING TO FIT BAR TO VEHICLE**



1. To fit a bar to vehicle, the plastic bumper, grill panel has to be cut.
2. The bumper will be cut later. Refer to step 8.

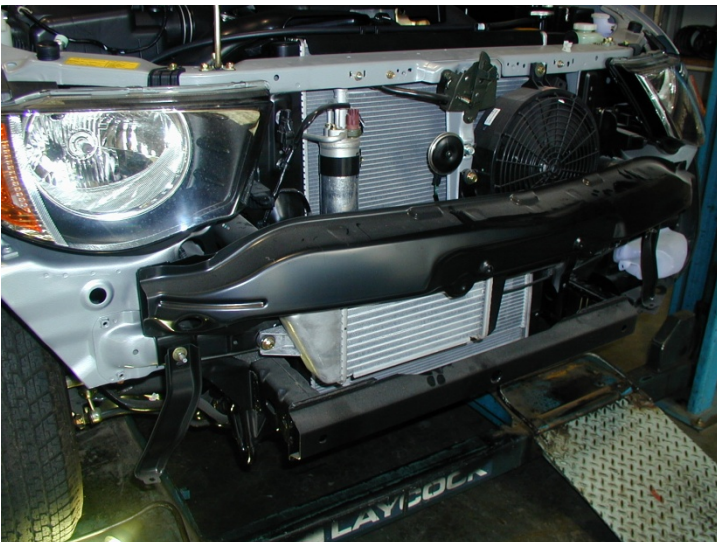

3. Remove grill and plastic bumper panel from front of vehicle.
4. When removing bumper, you will have to unclip flares half way back towards rear of vehicle.
5. Remove factory Stone Shield and retain with bolts.

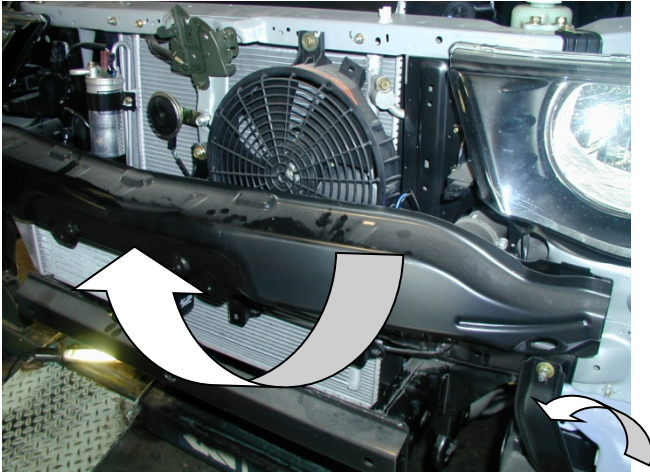

6. Remove cross member and mounting brackets from vehicle.

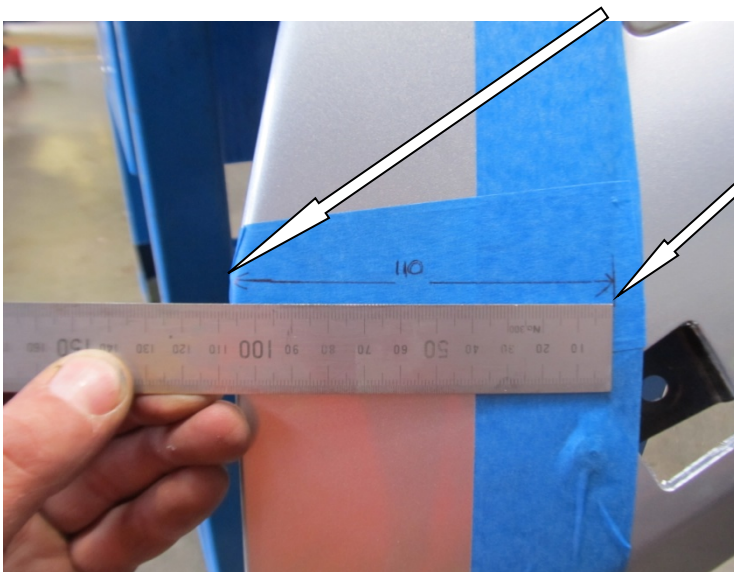

- Bumper Bar Cut**
7. Apply masking tape and measure and mark point 110mm down from indicator corner point on Bumper Bar.

8. Apply masking Tape and measure and mark point 10mm down from the centre of the License Plate landing.

9. Using masking Tape starting at outside point, create a line to join the three points with the edge of the tape, which will become the cutting edge.

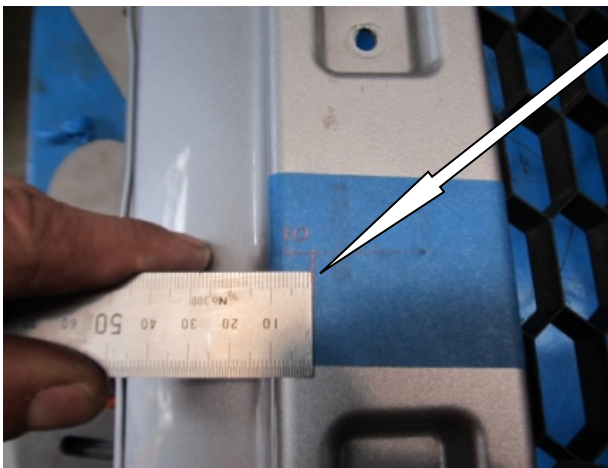

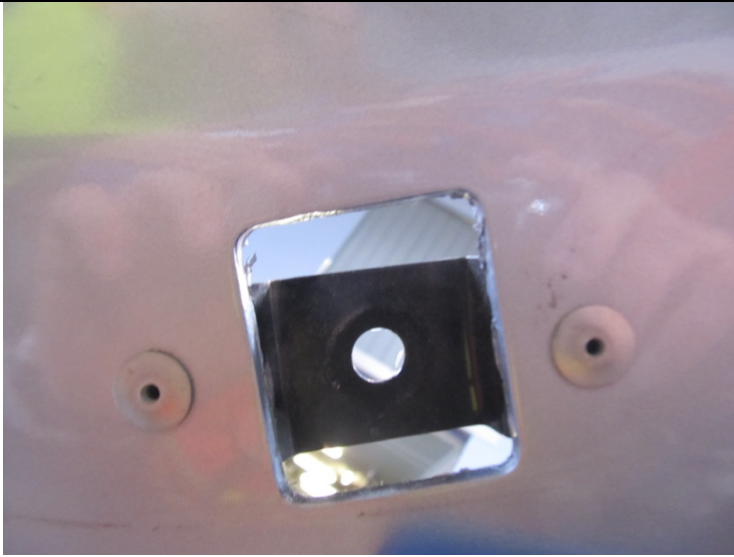

10. Remove metal Bumper Support Brackets by drilling out the Rivets.



11. Apply another strip of Tape opposite to protect the Bumper from being marked whilst cutting.
12. Using a small Hand Saw or Jigsaw cut along marked line from one side to the other. De bur sharp edges and remove tape.



13. Refit bumper back to vehicle and secure using originals fittings.
14. At this stage it is time to cut the lower section of the flares.
15. Temporarily refit front of flare back to front of vehicle.
16. Using the template supplied in bolt kit, fit to vehicle as per photo and secures using tape.
17. Draw a line to cut, and then remove template and mark out other side.



18. Lift flare away from vehicle, and cut along the drawn line, follow the same procedure on the other side.



19. When flare is cut off clean up with a file.



20. Now the next step is to mark out and cut off bumper panel under the flare.

21. Follow the flare line down as per photo and under bottom of flare.



22. Once again lift flare away from guard and cut out marked section.



23. Clean up with a file and refit flare.



24. When you are about to cut the LHS of vehicle, you must temporarily remove the washer bottle to enable cutting of the lower section of the guard panel. Refit flare and washer bottle after cutting.





25. At this stage the vehicle is ready to fit impact absorb mounting assembly.

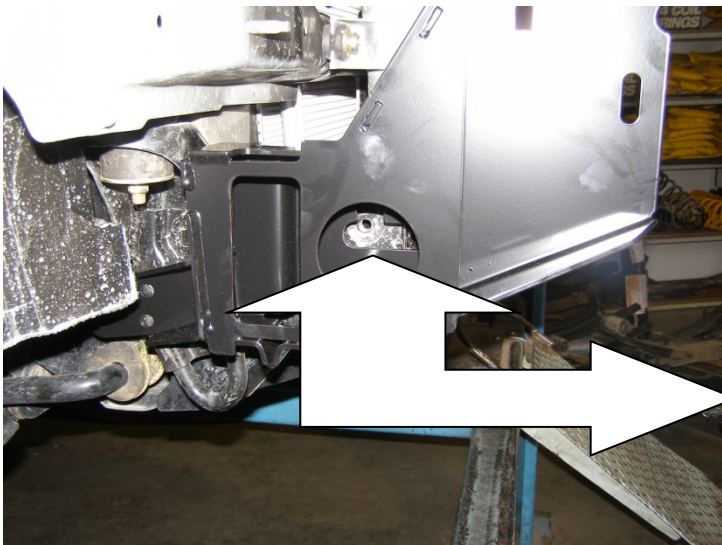

26. Fit impact absorber mounting assembly to vehicle chassis.

VIEWED FROM RHS

10MM CHASSIS CAPTIVE NUT

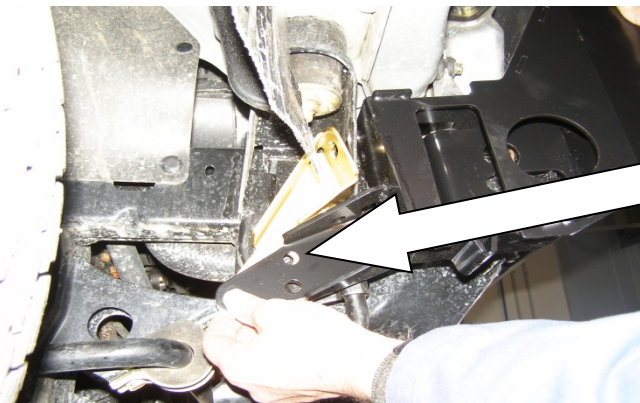

27. Before fastening impact absorber to vehicle, fit rear brace in between impact absorber and chassis and align rear holes with vehicle chassis holes.

28. RHS has a 10mm x 1.25 (fine thread) captive nut. Use top hole. Secure using a 10mm x 30mm x 1.25 bolts, spring washer and a 10mm flat washer. Finger tighten only.

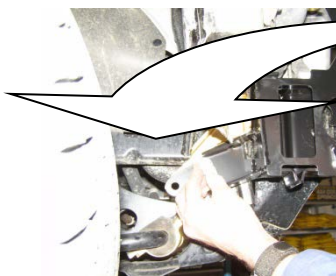

FITTING 10MM X 30MM X 1.25 BOLT



29.LHS side has a hole only, where a 10mm x 30mm 1.5 SEMS bolt is fitted and secured by a 10mm flange nut.

FINGER TIGHTEN

SEMS BOLT & FLANGE NUT

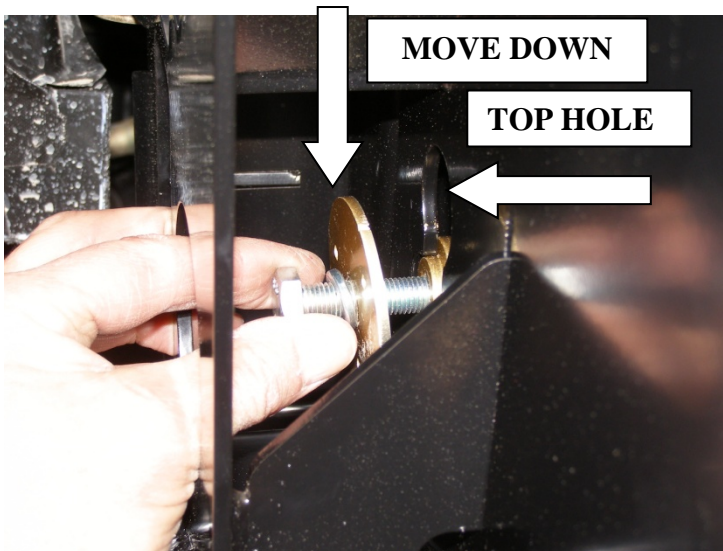

30.Using M10 x 50 x 1.25 mm bolt, 10mm spring washer, large flat washer and packer, feed into top hole and move down and screw bolt into captive nut in chassis.

FINGER TIGHTEN ONLY

VIEWED FROM RHS

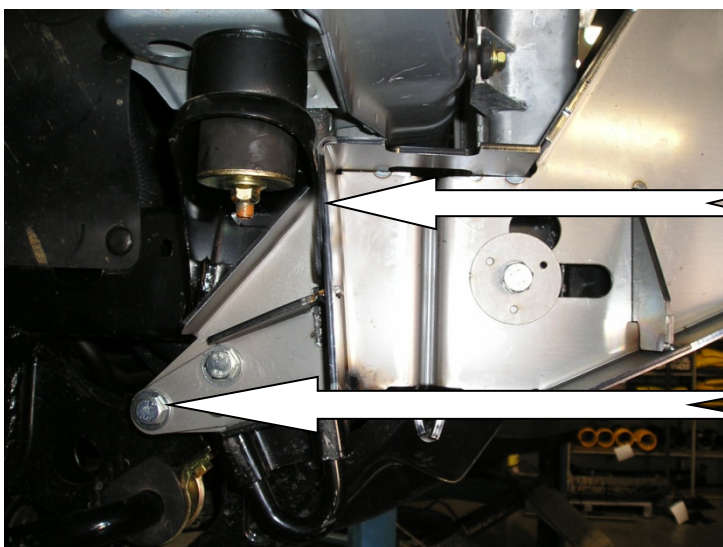

31.With the side and rear bolts fitted, fit the most rearward bolts to each side of the vehicle. Tighten all six bolts to specified torque.

NB. Before tightening, make sure that the two flanges are touching the body mount.

MOST REARWARD BOLT RHS

**DO NOT DRILL IN
SLOTTED HOLE**

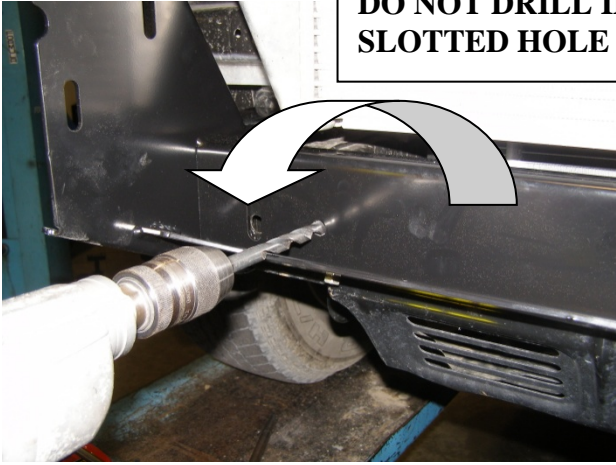

32. Using a 10mm drill bit, drill holes through chassis cross member, using holes in mount as a template.

33. Secure using 10mm X 30mm SEMS bolts, 10mm flange nuts. When the two bolts are fitted, tighten to specified torque.



34. Using a long 10mm drill bit, drill through vehicle body mount using hole in mount as a template, secure using 10mm X 30mm SEMS bolt, 10mm flange nut. When both sides of vehicle are done, tighten to specified torque.

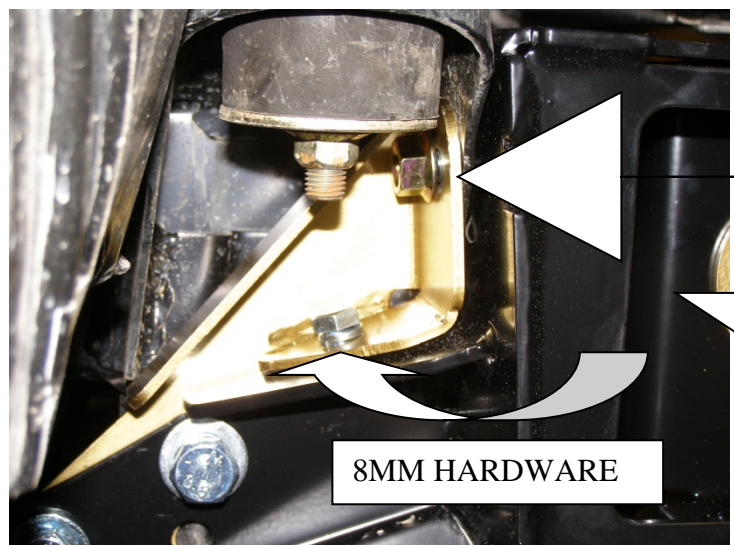

35. Lastly, fit M8 x 20mm bolt, spring washer, flat washer and 8mm flange nut to mounting assembly and tighten to specified torque.

**USE BRIGHT ZINC
M8 HARDWARE**

SEE PHOTO STEP 27

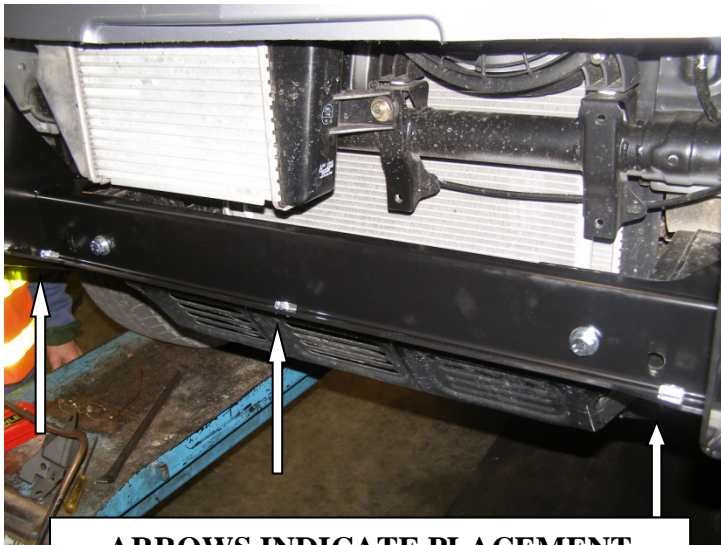

ARROWS INDICATE PLACEMENT

36. When impact absorber is securely bolted to vehicle, fit 8mm caged nuts to mounting assembly.

**SEE PHOTOS FOR
PLACEMENT OF
CAGED NUTS, 5 IN TOTAL.**

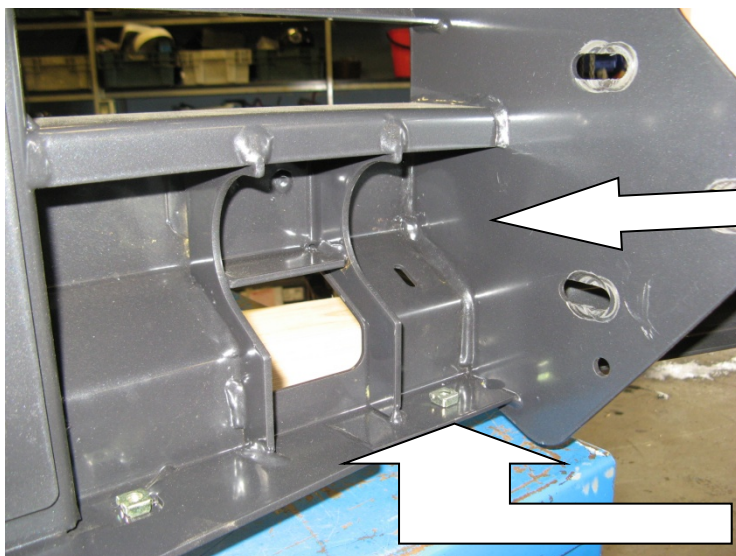

37. The next step is to fit the buffers to the bar using 6mm flange nuts, 6 per side. (DO NOT OVER TIGHTEN)

38. Fit 6mm caged nuts into lower flange of centre section of bar, 3 in total.



39. If you are not going to fit a winch to the bar, go to step 48

40. Firstly if a winch is going to be fitted to the bar, fit control box bracket to bar using 8mm hardware. Next fit number plate bracket to bar using 6mm hardware.

**IN BOTH CASES USE BRIGHT
ZINC PLATED HARDWARE.**

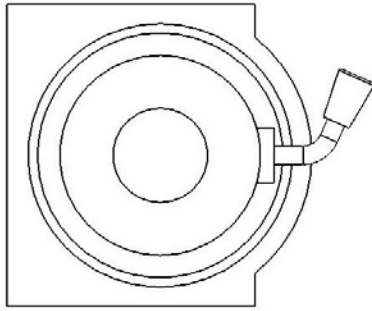

ORIGINAL

**VIEWED FROM
LHS OF**

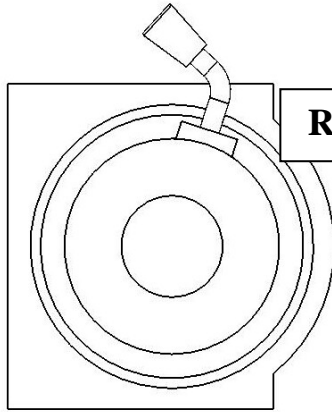

ROTATED

TO FIT A WINCH BAR

41. To fit an 8/9/9.5/000lb winch, rotate gearbox 72° counter clockwise.

Stand winch upright and undo the capped head screws and by lifting the gearbox only a couple of millimeters, rotate the gearbox. Once in position, refit all screws and tighten firmly.

WARNING: Do not lift gearbox more than a couple of millimeters.

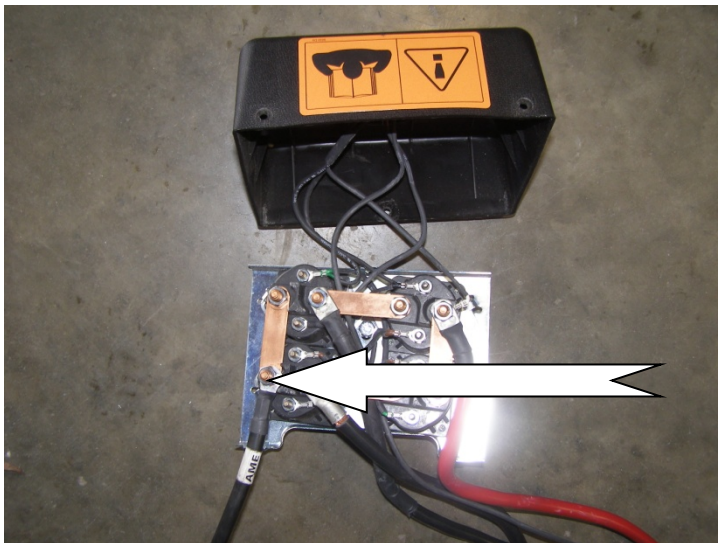

42. To fit control box to bar, you must change the arrowed lead (yellow tagged) in photo with the longer lead that is supplied in fitting kit. When all is fitted, screw plastic cover back onto control box.

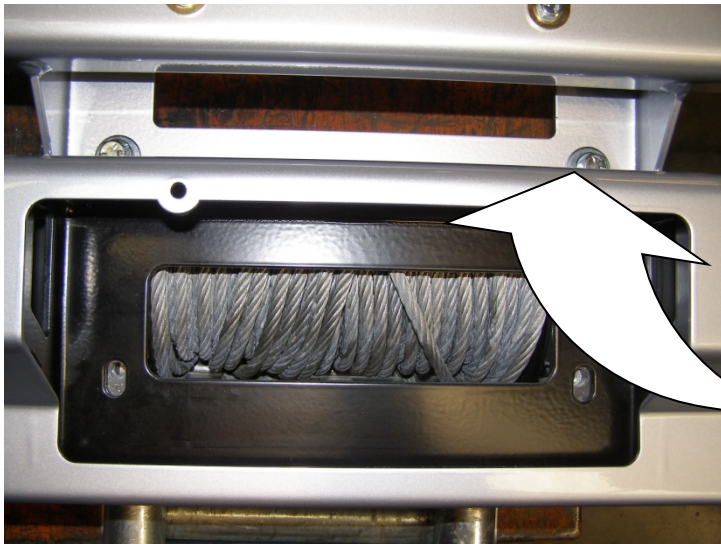

43. Lower bar down over winch, line up top holes first and secure using 3/8" hardware (1 1/2" x 3/8" bolts) flat and spring washers. (finger tighten only)

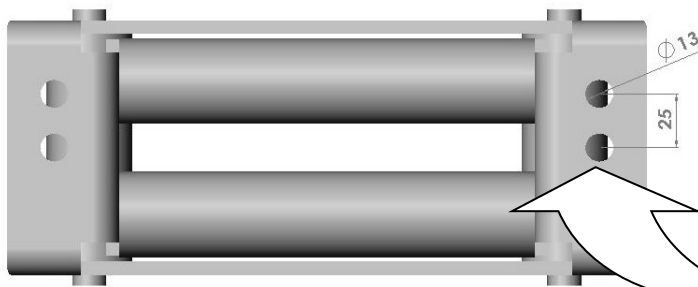

44. Drill two new 13mm holes in the roller fairlead provided in the kit, as shown on the adjacent picture.

Use new drill holes to bolt to bar.



45. Place roller fairlead over lower holes and again secure using 3/8" hardware (1 3/4" x 3/8" bolts) flat and spring washers.

46. Using circlip pliers remove lower circlips and push shaft upwards to be able to move rollers sideways.



- 47. Using screwdriver move vertical rollers sideways and tighten all bolts using socket and extension.**
48. Refit rollers and circlips.

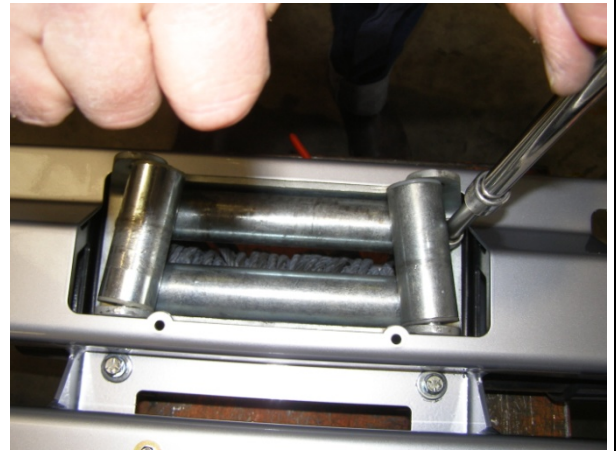

- 49. Fit rubber grommets into round holes in top of bar, then fit control box to control box bracket and pass cables through rubber grommet.**

ARROW INDICATES RUBBER GROMMETS.



- 50. Fit all 3 cables to their correct terminals and tighten. Refer to Warn installation instruction when wiring up winch. Fit plastic boots over terminals. Cable tie cables to bar as per photo to clear of all moving parts.**

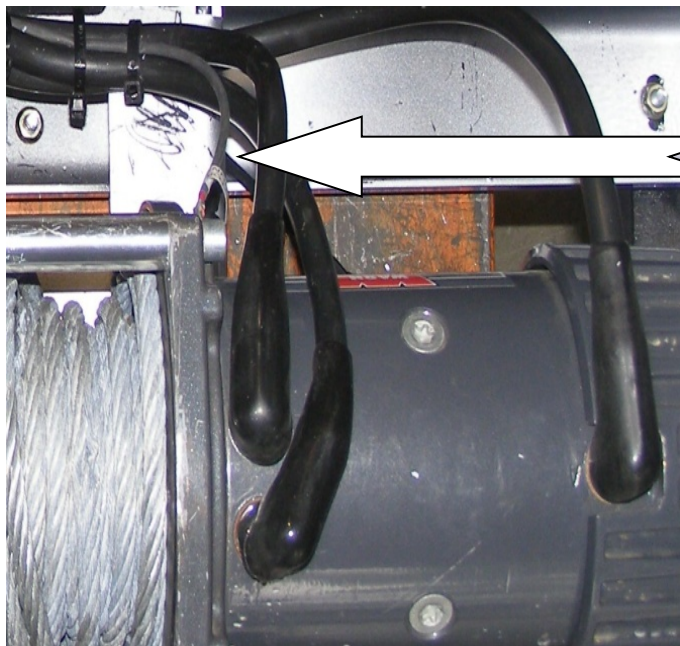

**51. Fit ground wire under winch tie rod.
(See Photo)**

GROUND WIRE

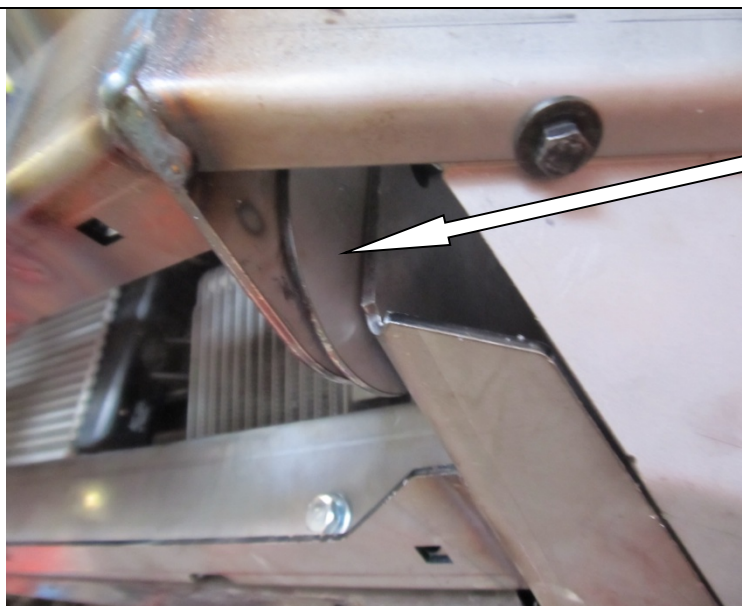

52. Before fitting the Bar, tape Packer to inside face of Chassis Mount (one per side at this stage) to hold in place.



**53. With the help of a friend, lift bar in between impact mounting bracket and align slots on mounting bracket to the slots on the side of bar. Secure using M12 x 1.75 x 35 coarse pitch bolts, Spring, flat washers and Flange nuts. Do not over tighten the bolts, allowing for bar adjustment.
Note: If the Bar is positioned too much to one side, one of the packers from previous step may have to be removed and added to the other, to centralise the Bar to the vehicle.**



- 54. Using body molding strip, fix to lower section of cut flare and trim to fit.**
- 55. At this stage it is time to adjust the position of the bar to under the flare gap which is 15, 20mm, and the parallelism between bar and vehicle, once the bar is in the desired position tighten the mounting bolts to specified torque.**



- 56. When all the six bolts have been tightened, using the lower holes from inside the bar as a template, drill through the impact absorber bracket using a 10mm drill bit and fasten with a 10mm SEMS bolt and a 10mm flange nut.**



- 57. Now using the fog light opening as access drill a 10mm hole in the top of the bars upright using the hole in the impact absorbers mounting blade as a template, the pin using M10 SEMS bolt and flange nut, tighten bolts to specified torque.**

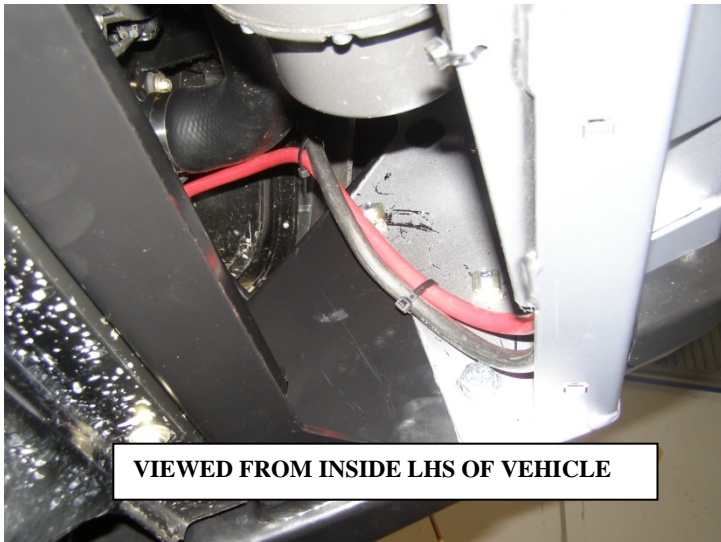

VIEWED FROM INSIDE LHS OF VEHICLE

58.When bar is secured to mounting bracket, connect winch cables to battery and cable tie cables together to clear of all moving parts, sharp edges and hot parts.

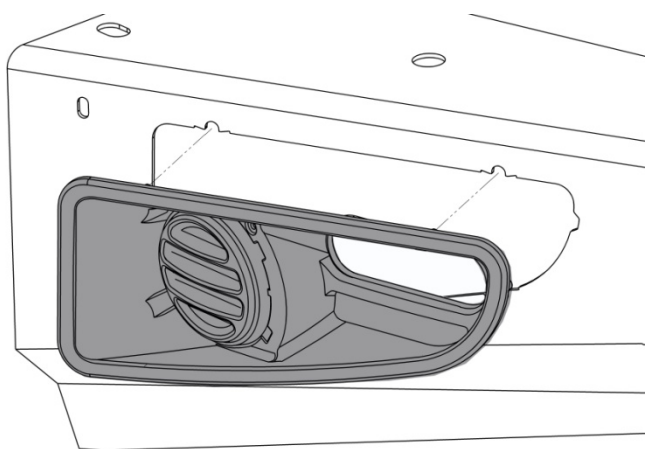

59.Assemble and install combination light surrounds (p/n 3163015) as per instructions no. 3786421 supplied with surround kit. **Note:** Optional fog lamps can be installed at this point as per fitting instruction no. 3783315 supplied with fog lamp kit no. 6821201. Wire the combination lamp to the vehicles indicator and clearance lamps.

Caution: Cable tie all cables together and keep all cables clear of sharp edges and moving parts.

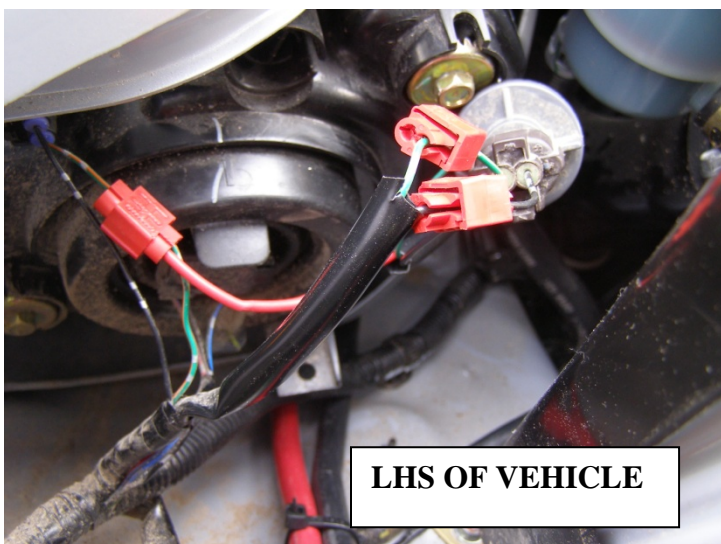

LHS OF VEHICLE

60.Pull indicator loom up into engine bay to scotch lock wiring onto vehicle indicator/clearance lamps

Summary of Wire Connections

FUNCTION	TURN SIGNAL HARNESS	VEHICLE PARK LAMP	
		RIGHT	LEFT
PARK LAMP	RED	GREEN/WHITE	GREEN/BROWN
		VEHICLE INDICATOR	
		RIGHT	LEFT
EARTH	BLACK	BLACK	BLACK
INDICATOR	GREEN	GREEN	GREEN

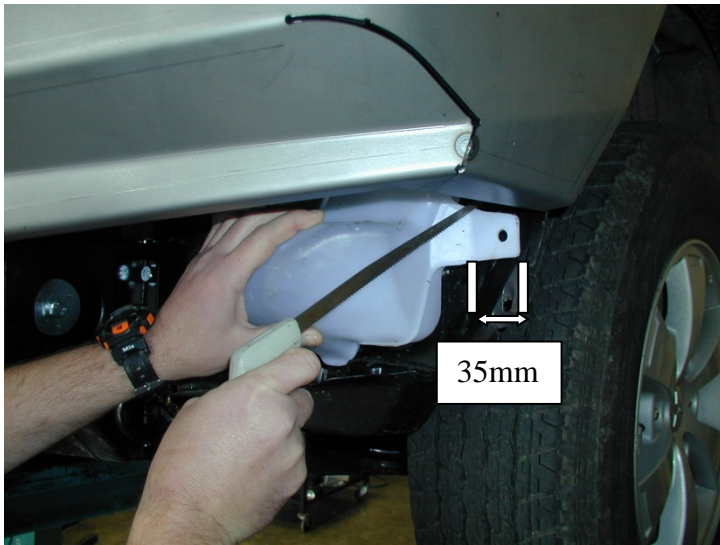

61. Before fitting under wing surround panels to bar, you must cut back washer bottle tag, 35mm to give clearance of panel.

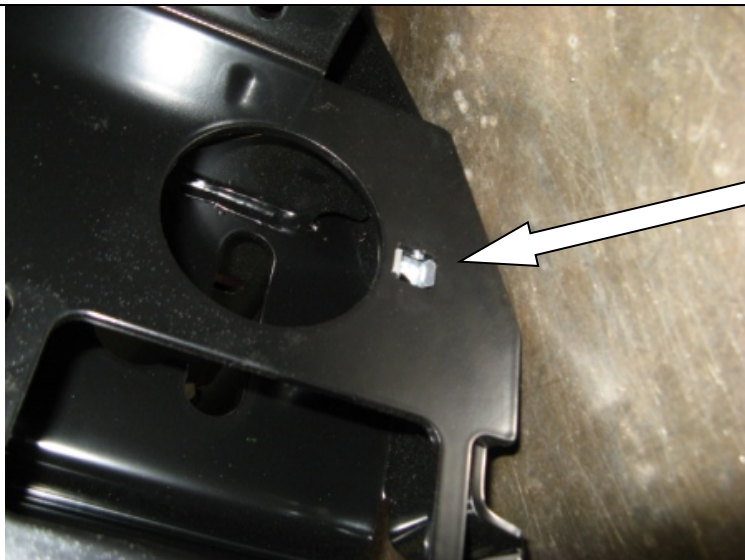
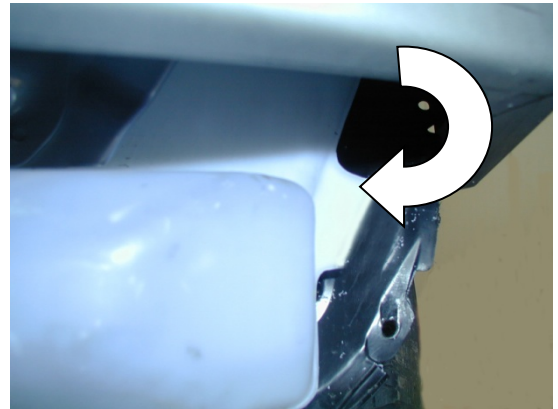

62. The next step is to fit the wing under panels, firstly M8 cage nuts must be fitted to the mount assembly as shown.



63. Also M8 cage nuts must be fitted to the adjustable wing under panel brackets as shown.

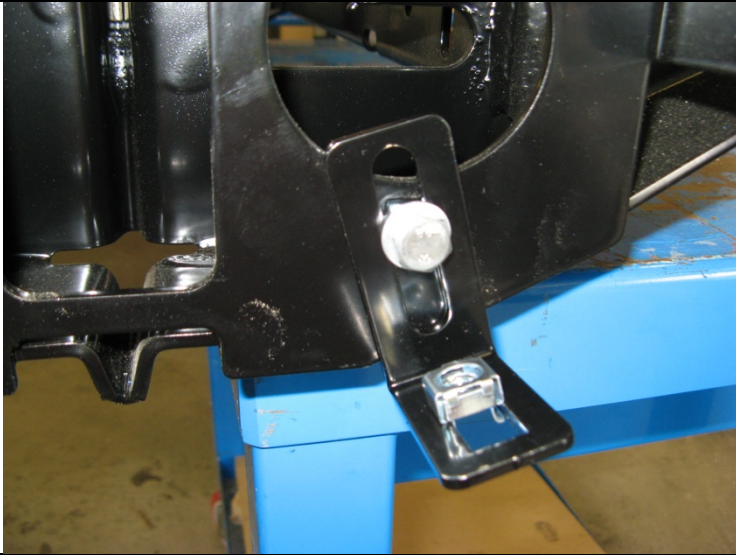

64. At this stage loosely fit the adjustable wing under panel bracket to the mount assembly.

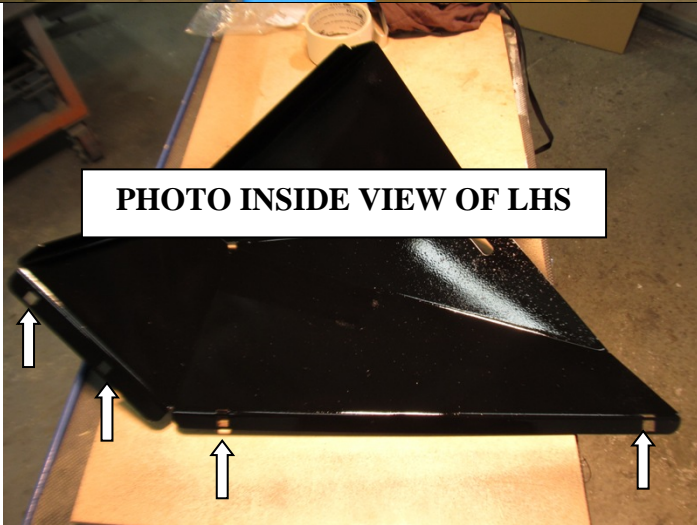

65. Fit M6 Cage nuts into both L/RHS under Wing Panels. (4 per side)

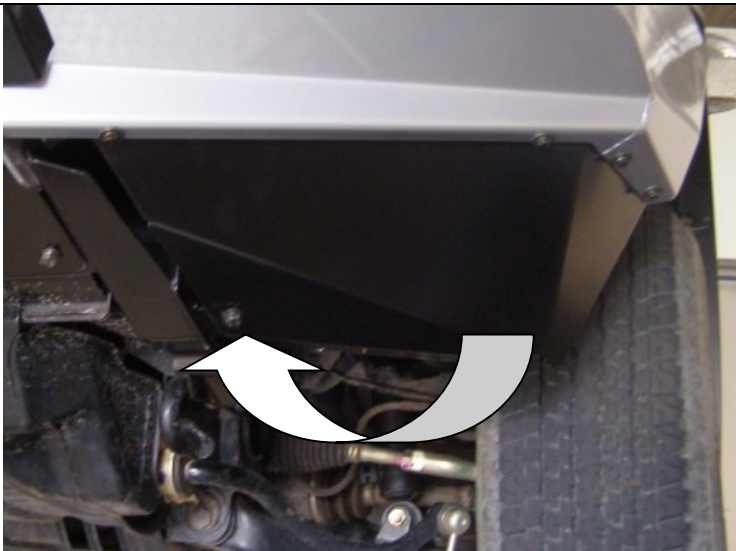

66. Now position the adjustable wing under panel bracket so that it aligns with the lower slot on the wing under panel and tighten the bracket in place to specified torque.
67. Then securely bolt the lower wing under panel to the adjustable bracket.

Fit M8 black hardware as per arrow.

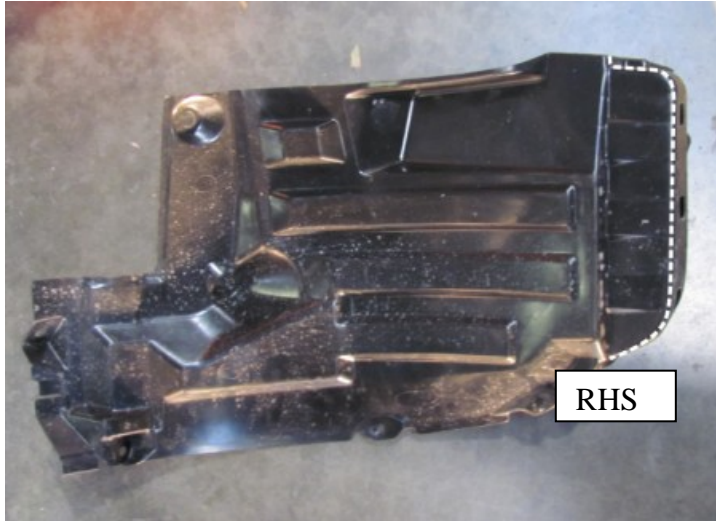

68. Remove plastic inner guards and cut along marked line.



Discard hatched area



69. Refit the fender liner to the vehicle. Press the fender liner up to the wing under panels and using a scribe, score a line on the liner against the side and lower edges.

70. Trim to the scored line with a sharp knife or small saw.



71. Push the fender liner past the Wing Panel returns.



72. Fit air deflector under centre of bar using M6 black hardware at the front of bar and M8 hardware at the rear of bar.



M6 HARDWARE

M8 HARDWARE

Fit number plate to number plate bracket using 6mm hardware



73. If you are not having a winch fitted to the bar, fit plastic grommets into the square holes and secure using black pan head screws to secure number plate to bar as per photo.

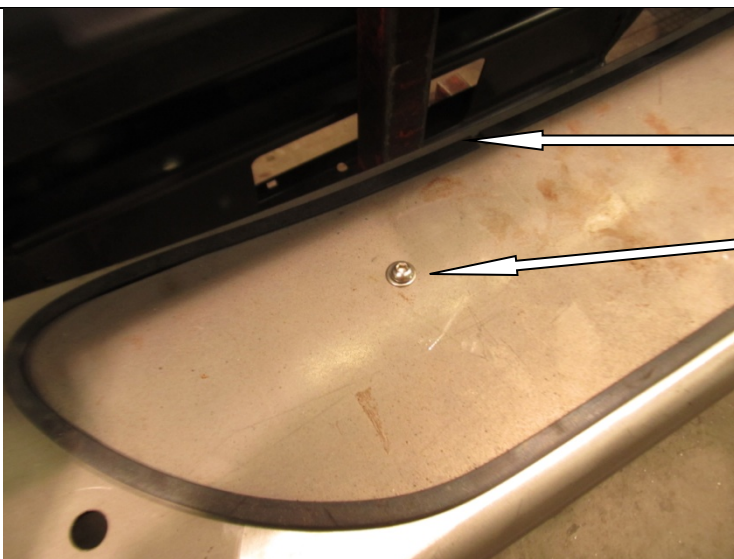

74. (If not fitting a winch) Starting from the centre of the back edge of the Panel Cover, fit rubber extrusion around the edge and trim end to suit.
75. Fit Panel to the Bar using M6 Button Head S/S screws making sure to place S/S Washer under screw head as shown and fasten using M6 Flange Nuts.

FINAL PRODUCT SHOWN ON VEHICLE

